



TECHNIMOUNT
EMS®

BRACKET PRO SERIE® 25 WOB - FL

USER MANUAL

SAFETY AND FLEXIBILITY
WHERE IT MATTERS MOST

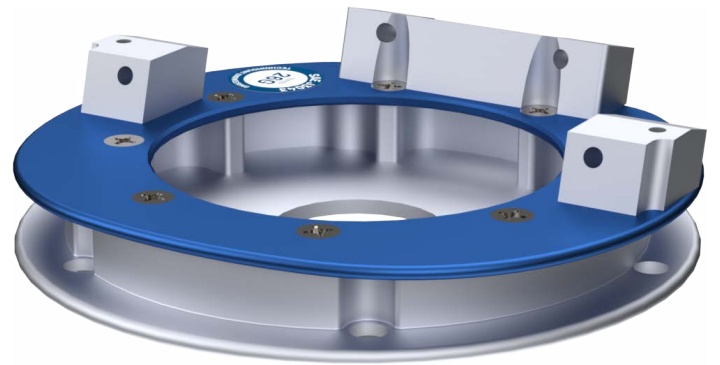

Copyrights

Copyright 2025 Technimount E.M.S. Holding Inc. is an affiliated company of Technologies CGC Inc. All Rights Reserved. No part of this publication may be reproduced, transmitted, transcribed, backed-up on a retrieval system, translated in any language, modified in any form or by any means, without the written permission of Technimount or its affiliate companies.

Trademarks

Product and medical device manufacturer names are Trademarks™ or Registered Trademarks® of their respective holders.

- Technimount EMS® and Bracket Pro Serie® are registered trademarks of Technologies CGC Inc.
- ZOLL® X Series® are registered trademarks of ZOLL Medical Corporation.
- Oxivir® is a registered trademark of Diversey.
- Lavo® is a registered trademark of KIK Holdco Company, Inc.

For any issues with your Technimount product, its components, or for any technical questions during the installation, operation, or maintenance, please contact Technical Support at techsupport@technimount.com.

Contact Information

Technimount E.M.S. Holding Inc.

C/O: Regulatory Affairs

3770 Jean Marchand Street, Suite 100-C

Quebec (Quebec) G2C 1Y6

Canada

customerservice@technimount.com

techsupport@technimount.com

legal@technimount.com

www.technimount.com

T + 1 581 700-6613

TF + 1 888 639-2758 (North America)

Table of Contents

Copyrights	ii
Trademarks	ii
Contact Information	ii
1. General Mentions and Considerations	5
..... 1.1. Intended Use	5
..... 1.2. User Competency	5
..... 1.3. Warranties	6
..... 1.3.1. Warranty Policy	6
..... 1.3.2. Limited Warranty	6
..... 1.3.3. International Warranty Clause	6
..... 1.3.4. User Liability	7
..... 1.4. Claims	7
..... 1.4.1. Damaged or Defective Merchandise	7
..... 1.4.2. Return Policy	7
..... 1.4.3. Return of Material Authorization (RMA)	8
..... 1.4.4. Claim Process	8
2. General Safety Guidelines	9
..... 2.1. Symbols and Definitions	9
..... 2.2. Labels	10
..... 2.3. Safety Measures	11
3. Technical Specifications	12
4. Bracket Pro Serie 25 WOB - FL Orientation Diagrams	13
5. Bracket Pro Serie 25 WOB - FL Illustrated Parts	15
6. Operate the Bracket Pro Serie 25 WOB - FL	17
..... 6.1. Install the Bracket Pro Serie 25 WOB - FL in the Standard Surface Base	17
..... 6.2. Remove the Bracket Pro Serie 25 WOB - FL from the Standard Surface Base	18
Annex I EMS and clinical personnel Skills Assessment	19
Annex II Unpack the Bracket Pro Serie 25 WOB - FL	21
Annex III Prepare the support bracket	23
..... Required Installation Time	23
..... Required Tools	23
..... Required Parts	23

..... Install the ZOLL X Series monitor/defibrillator on the Bracket Pro Serie 25 WOB - FL 24

Annex IV Maintenance..... 29

..... Maintenance Frequency 30

..... Required Tools 30

..... Tested Cleaning Solutions 30

..... Maintenance Plan 31

..... Illustrated Inspection Points 34

Annex V Replacement Parts/Kits 35

1. General Mentions and Considerations

The Bracket Pro Serie 25 WOB - FL user manual includes detailed product information, standards and guidelines to assist the administrator/manager/supervisor and biomedical technician (or equivalent) with the unpacking, assembling (when indicated) and maintenance of the Technimount product. It also includes specific user-related information to assist trained EMS and clinical personnel with effectively operating the support bracket.

Please read the user manual thoroughly to fully assess, comprehend, then relay its content to EMS and clinical personnel during training, to warn them of any potential danger of its abuse, how to safely use the product and provide a safe environment for patients as well as themselves. Your existing protocols should be updated to include the Technimount product(s) standards, guidelines, requirements and safety recommendations included within this documentation. The user manual should remain available to users when needed and relayed if the product is subsequently sold.

NOTE : Technimount continually seeks advancements in product design and quality. While the user manual contains the most updated product information available at the time of printing, it may contain minor differences from the current version, including image references. For more information, please contact Technical Support at techsupport@technimount.com.

NOTE : Technimount reserves the right to change part numbers and products without notice. Please contact Customer Service at customerservice@technimount.com to ensure product options and availability.

1.1. Intended Use

The Bracket Pro Serie 25 WOB - FL is designed to aid trained EMS and clinical personnel move the ZOLL X Series monitor/defibrillator that is essential to patient care during emergency medical services and critical care.

1.2. User Competency

To safely operate the support bracket, EMS and clinical personnel must have the required skill level. Training should be given to EMS and clinical personnel, taking in account the skill level that is necessary to comply with their function and level of interaction with the Bracket Pro Serie 25 WOB - FL:

- **Proficient (trained EMS and clinical personnel):** Has received the required training, is sufficiently knowledgeable to safely operate the product and have passed the skills assessment (refer to « Annex I EMS and clinical personnel Skills Assessment » on page 19).

NOTE : Any member of the EMS and clinical personnel who has not received the required training and lacks the knowledge needed to safely operate the support bracket must not use the product.

- **Expert (administrator/manager/supervisor):** Has in-depth knowledge and product comprehension, and is familiar with standards and guidelines. Skilled to train EMS and clinical personnel on how to safely use the product.
- **Advanced (biomedical technician or equivalent):** Has extensive mechanical experience. Skilled to perform the unpacking, assembly, safety checks and condition-based maintenance procedures as detailed in « Annex IV Maintenance » on page 29, basic troubleshooting, upgrade procedures and replacement procedures.

1.3. Warranties

1.3.1. Warranty Policy

This statement constitutes Technimount's entire warranty policy with regards to Technimount products. Technimount makes no other warranty or representation, neither expressed nor implied, except as stated herein. There is no warranty of merchantability or warranty of fitness for any particular purpose. Under no circumstances will Technimount be held liable hereunder for incidental or consequential damages, arising from or in any manner, related to sales or use of any such product.

Technimount E.M.S. Holding Inc. guarantees to the original "Purchaser" of the "Product" with which this "Limited warranty" is included, that the product will be free from "Defects" in workmanship and materials under normal use for a "Warranty period" of one (1) year from the product purchase date by the purchaser. During the warranty period, the product will be repaired or replaced according to the "Limited warranty" without charge to the purchaser for parts or labor. The parts and product may be repaired or replaced with new or refurbished parts or products. Herein this Limited Warranty, "Refurbished" means parts and products which have been returned to the factory, specifically. If the product is repaired or replaced within the warranty period, the greater of the remaining warranty period will apply, or three (3) months from the date of repair or replacement. If the product is repaired or replaced after the warranty period has expired, the warranty period for the repair or replacement will expire three (3) months after the repair or replacement date.

1.3.2. Limited Warranty

Technimount products are intended to retain medical devices in place in the case of a single emergency landing or single crash impact. Technimount products must not be reused if involved in a single emergency landing or a single crash impact and must thereafter be replaced. If the end user uses a Technimount product following a single emergency landing or a single crash impact, it is at the end user's own risk and Technimount will not be held liable.

The limited warranty does not apply to normal wear that could result from normal use. It does not apply when the product or any of its components have been disassembled or repaired by someone not authorized by "Technimount". It does not cover repair or the replacement of any product or part thereof damaged by neglect, misuse, moisture, liquids, exposure to heat, accidents, abuse, and non-compliance with the instructions for installation and use provided with the product. It does not cover physical damage to the surface of the product. The decision to repair, replace or refuse the coverage is final and at the sole discretion of Technimount, without any compensation or obligation from Technimount. The product defined as a "support bracket" or "bracket" is specifically designed to fill this requirement. Any other use will void the warranty and Technimount shall not be held liable on any claim if the product has been modified or adapted for use.

1.3.3. International Warranty Clause

This warranty abides by the Canadian domestic policy. Warranty outside Canada may vary by country. Please contact Customer Service at customerservice@technimount.com for more information.

1.3.4. User Liability

The purchaser and administrator are responsible to validate regulations and standards for safety in their region, to comply with applicable safety regulations. Technimount is not responsible to inform the purchaser or the administrator of any applicable legislation for safety in their area.

The administrator is responsible for providing proper training to any personnel who will install, operate and perform maintenance on Technimount products.

1.4. Claims

1.4.1. Damaged or Defective Merchandise

ICC Regulations require that claims for damaged merchandise must be made with the carrier within fifteen (15) days of the reception date. **Do not** accept damaged merchandise unless such damage is noted on the delivery receipt at the time of reception. Upon prompt notification, Technimount will file a freight claim with the appropriate carrier for damages incurred. Claims are limited in amount to the actual replacement cost. If the claim has not been received by Technimount within the fifteen (15) day period following the date of delivery, or the damage was not noted on the delivery receipt at the time of receipt, the customer will be responsible for the full payment of the original invoice.

Claims for any short or broken merchandise must be made within thirty (30) days of invoicing. For details, refer to the claim process or contact Customer Service at customerservice@technimount.com.

1.4.2. Return Policy

Technimount products may be returned up to sixty (60) days from the reception date, if:

- The received product does not match what was originally ordered.
- The product does not meet the Technimount technical sheet specifications.
- The product is not compatible with the system on which it was intended to be installed on.

To return a Technimount product,

- A Return of Merchandise Authorized (RMA) must be requested and approved by Technimount prior to returning the product.
- Products must be returned undamaged and in its original packaging, appropriately identified with the approved RMA number. Returns will not be approved on a modified or damaged item.
- Charges may apply if the package received is damaged or items are missing.
- Purchaser is responsible for a restocking fee (refer to Table 1).

Table 1: Restocking fees

RESTOCKING FEES	
Prior to thirty (30) days	10%
Prior to forty-five (45) days	25%
Prior to sixty (60) days	30%

For any manufacturing defect, refer to the conditions within the warranty policy or contact Customer Service at customerservice@technimount.com for additional information.

1.4.3. Return of Material Authorization (RMA)

The Technimount Customer Service department is responsible for all merchandise returns and will provide a Return of Merchandise Authorization (RMA) number, upon approval. The RMA must be printed and placed on the returned merchandise. Technimount reserves the right to charge shipping and restocking fees (refer to Table 1) for the returned items. Special, modified, or discontinued items are not subject to returns.

1.4.4. Claim Process

Upon reception of the returned merchandise, a thorough inspection will be performed. If the merchandise is compliant with the return policy or it is found that the product is defective, Technimount will take corrective actions and close the claim. If, however, it is found that the product is not defective, but rather misused or abused, the product will not be covered by the warranty. Details of our findings and conclusions will be provided shortly thereafter. To submit a claim, contact Customer Service at customerservice@technimount.com to obtain a Return of Material Authorization (RMA) form and return instructions.

2. General Safety Guidelines

Always read and abide by all the safety guidelines identified within this document. Pictograms, safety symbols and labels are used to alert the user to a potentially hazardous situation, which, if not avoided, may result in minor or moderate injury to the patients or EMS and clinical personnel, or damage to the product. This includes the special care necessary for the safe and effective use of the Technimount product to avoid damage that may occur from use or misuse. The terms "Warning" and "Caution" herein carry special meaning and should be carefully reviewed.

WARNING – Indicates a hazardous situation that, if not avoided, could result in death or serious injury.

CAUTION – Indicates a hazardous situation that, if not avoided, could result in minor or moderate injury.

2.1. Symbols and Definitions



WARNING – Hand Crush/Pinch Point

Indicates an area where mechanical components could move toward each other and might result in a potential crush/pinch hazard.



WARNING – Do Not Step

Indicates an area where there is potential risk of tipping if the user steps, stands, sits or rests his/her foot that could result in serious injuries to the patients or EMS and clinical personnel, or damage to the product.



CAUTION – Safe Working Load (SWL)/Load Balance

Indicates the total maximum charge for a safe use of the product.



CAUTION – Safe Handling and Operation

Alerts the reader to pay special attention to the recommendations for safe use of the product, and of potentially hazardous situations that could result in minor injuries to the patients or EMS and clinical personnel. This includes the special care necessary for the safe and effective use of the product to avoid damage that may occur from use or misuse.



CAUTION – Safe Practice

Alerts the reader to pay special attention to the recommendations and methods outlining how to safely operate the product to minimize risks to the patients, EMS and clinical personnel and the product.



CAUTION – General Mandatory Action

Call for action. Alerts the reader to potential risk to the patients or EMS and clinical personnel not following the mandatory action specified by the supplementary sign.



CAUTION – Follow Instructions for Use

Call for action. Reminds the reader to consult the user manual for information.



CAUTION – Two (2) Person Lift

Heavy load. Alerts the reader to a two (2) person lift carrying technique recommendation based on the weight and/or size of the product.

2.2. Labels

Labelling on the surface of the Technimount product, quickly identify potential risks and provides information to the user. A manufacturing label, including the serial number and safe working load (Figure 1), can be seen on the Technimount product.

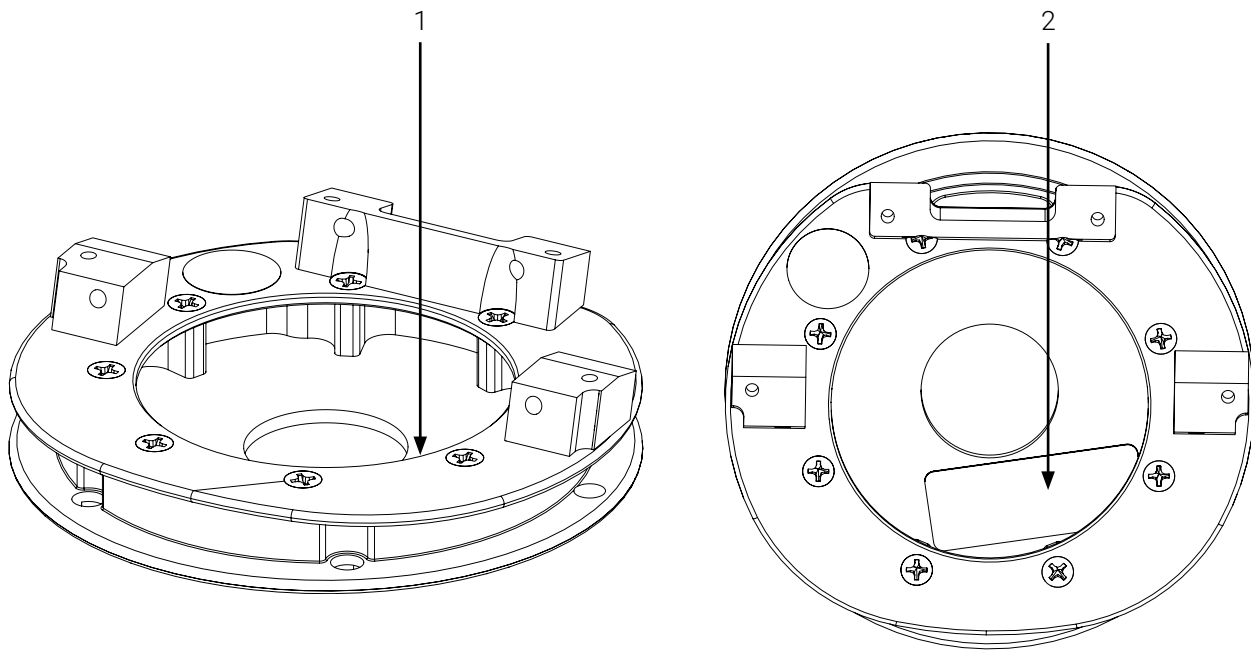

- | | |
|--|-----------------------------------|
| 1. Manufacturing label (on the standard bottom disc, inside the bracket) | 2. Manufacturing label (top view) |
|--|-----------------------------------|

Figure 1: Location of the manufacturing label

2.3. Safety Measures

Carefully read all the safety measures herein before operating the Technimount product, relay to EMS and clinical personnel during training, and include in your existing protocols.

More specific safety measures intended for biomedical technicians (or equivalent) relating to the safety checks and conditioned-based maintenance can be found in « Annex IV Maintenance » on page 29.



WARNING – Risk of Injury

- **Do not** use the Bracket Pro Serie 25 WOB - FL if the screws located under the support bracket are loose or missing, to prevent undue risk to the medical device, patients, and EMS and clinical personnel.
- Always use compatible mounting systems and medical devices when applicable, to avoid unpredictable functioning resulting injury to the patients or EMS and clinical personnel. Refer to the « Technical Specifications » on page 12 for compatibilities.
- Improper use of the Technimount product may damage it or cause injury to the patients or EMS and clinical personnel.
- If any serious incident occurs with the support bracket, immediately stop using the product, report this incident to Technical Support at technicalsupport@technimount.com and the applicable regulatory agency.



CAUTION – Safe Practice

- Practice safely operating the support bracket until the manipulations have been perfected, before use with patients. Improper use of a Technimount product may damage it or cause injury to the patients or EMS and clinical personnel.
- Regulations and standards for safety are the sole responsibility of the end user. Ensure that the installation specifications meet the local and regional compliance requirements before use.
- Refer to your protocols and the user documentation provided with the medical device for the safety guidelines and safe use with the support bracket.



CAUTION – Safe Handling and Operation

Always ensure that the medical device is secured in the support bracket before it is moved to avoid risks of damage, equipment falling, or injuries to the patients or EMS and clinical personnel.



CAUTION – Safe Working Load/Load Balance

Do not overload the support bracket to avoid tipping incidents or risks of collapsing. The total Safe Working Load (SWL) is 12 lb (5.5 kg).



CAUTION – Follow the Instruction for Use

- Always read and abide by all the safety guidelines identified, as well as follow instructions provided within the user manual of the Technimount product.
- The Bracket Pro Serie 25 WOB - FL is designed specifically to support the ZOLL X Series monitor/defibrillator. Refer to the manufacturer's user documentation for the safety guidelines and safe use.

3. Technical Specifications

Product Name	Bracket Pro Serie® 25 WOB - FL
Description	Support bracket designed to aid trained EMS and clinical personnel move the ZOLL® X Series® monitor/defibrillator that is essential to patient care during emergency medical services and critical care
Product Code	100-16-XZ-WOB-FL
Operating Environment	EMS/CCT (air and ground)
Compliance	<ul style="list-style-type: none"> - Tested in compliance with SAE J3043 and AMD-028 - Designed to comply with FAA, 14 CFR § 23, 25, 27 & 29 (applicable sections)
Expected Service Life	5 years
Compatible Stretcher	N/A
Compatible Mounting System	<ul style="list-style-type: none"> - Standard Surface Base - Extended Surface Base - Universal Mounting Base
Compatible Medical Devices/ Accessories	ZOLL® X Series® monitor/defibrillator (w/o bags)
Dimensions (L X P X H)	6.47 in. X 6.47 in. X 1.51 in. (15.24 cm X 15.24 cm X 2.54 cm), w/o medical device
Weight	1.3 lb (0.59 kg), w/o medical device
Composition	<ul style="list-style-type: none"> - Bracket Pro Serie® 25 WOB - FL: aluminum, stainless steel - Standard bottom disc: refer to the user documentation
Total Safe Working Load (SWL)	12 lb (5.5 kg)
Operating Temperature	- 31° F to 113° F (- 35° C to 45° C)
Cleaning Solutions	<ul style="list-style-type: none"> - Oxivir®, 5% Hydrogen Peroxide with Peracetic Acid (AHP) - Lavo® 12, 10 000 ppm Sodium Hypochlorite - TNT-100, 5% Quaternary Ammonium Compound - Spectro-Sept, 5% Ethyl Alcohol - Spectrol, 5% EDTA salt
Options	N/A

4. Bracket Pro Serie 25 WOB - FL Orientation Diagrams

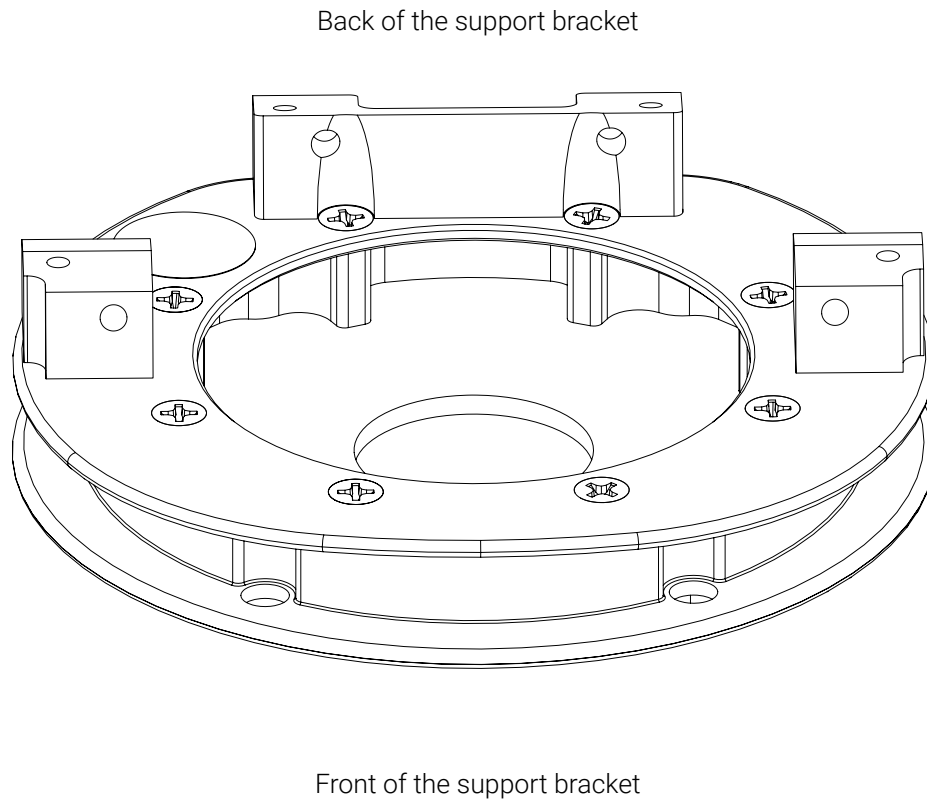
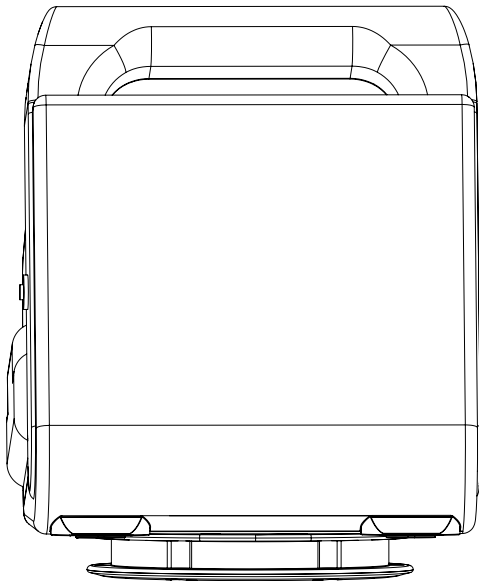
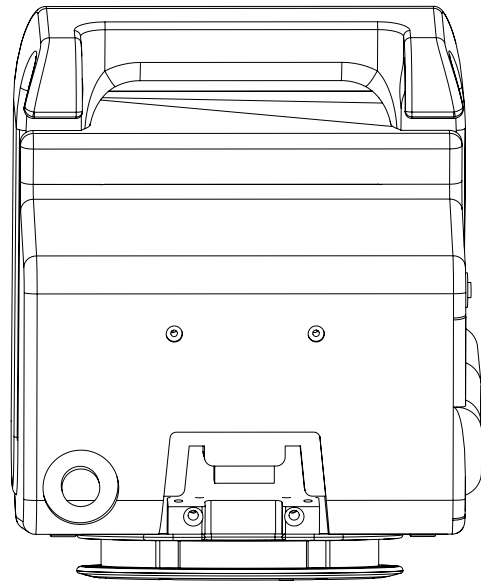

Figure 2: Bracket Pro Serie 25 WOB - FL orientation diagram



Front of the support bracket



Back of the support bracket

Figure 3: Bracket Pro Serie 25 WOB - FL orientation diagram with medical device

5. Bracket Pro Serie 25 WOB - FL Illustrated Parts

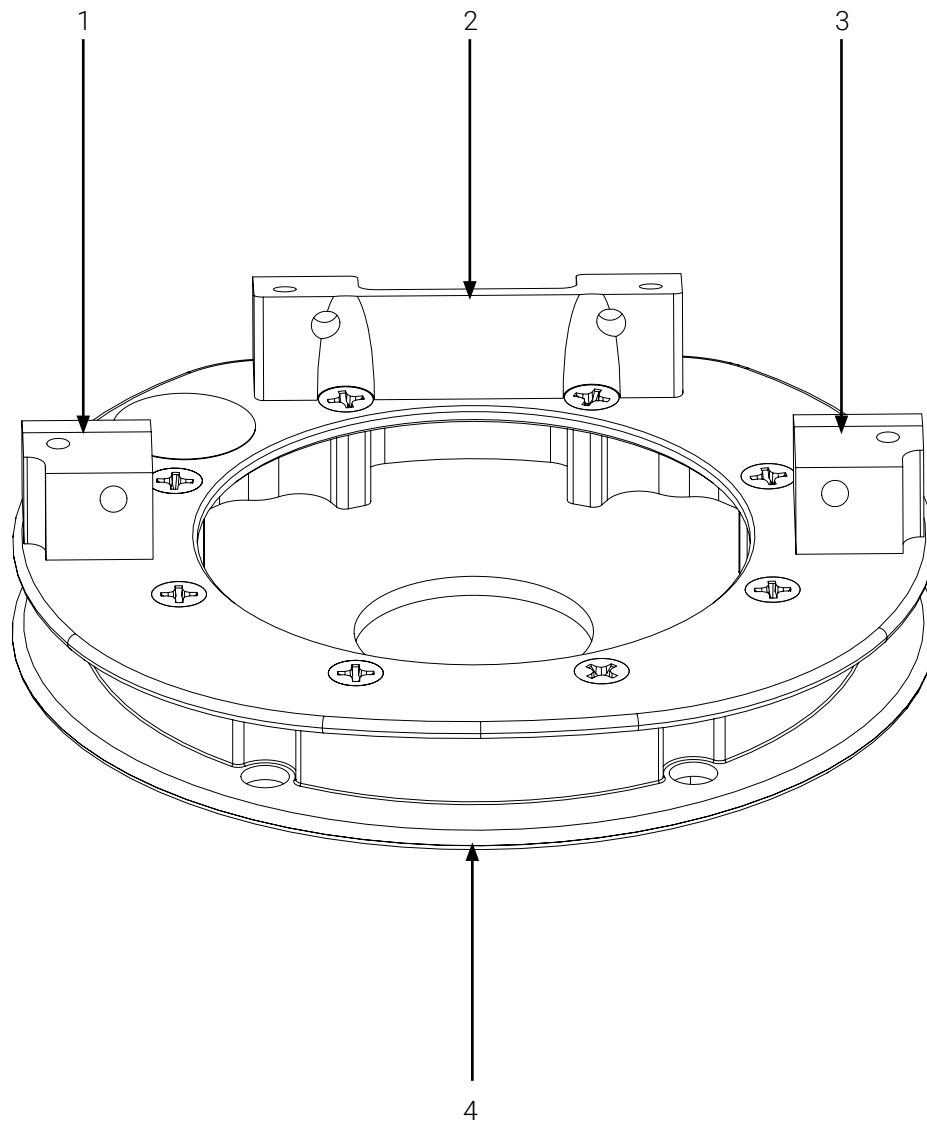

- | | |
|------------------------|-------------------------|
| 1. Left mounting block | 3. Right mounting block |
| 2. Rear mounting block | 4. Standard bottom disc |

Figure 4: Bracket Pro Serie 25 WOB - FL components

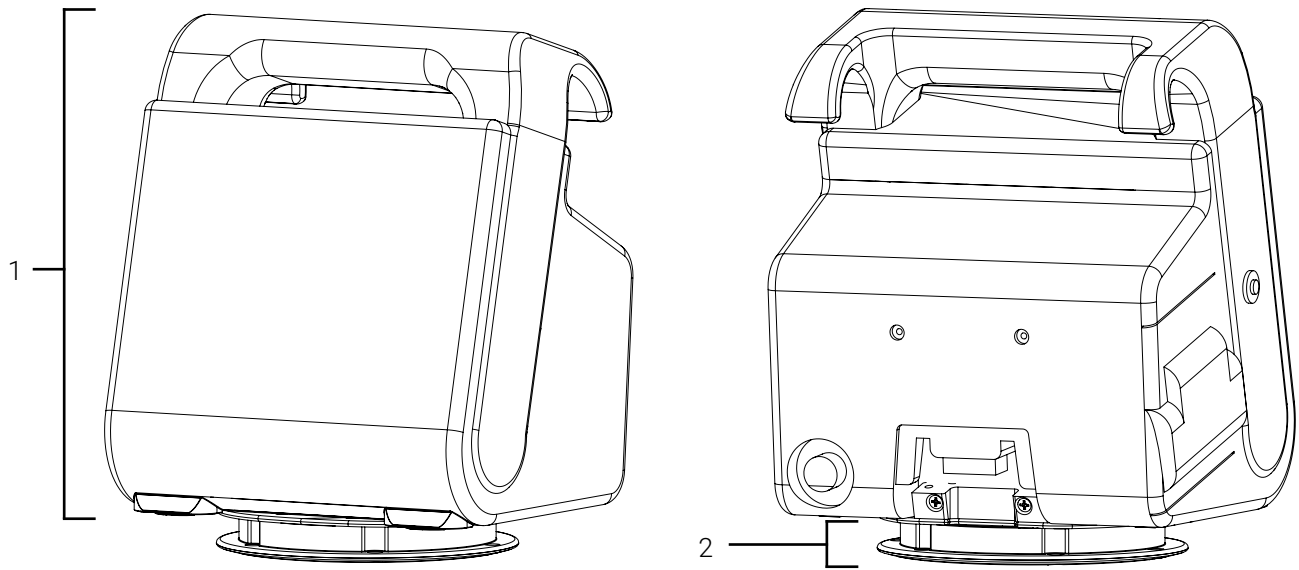

- 1. Medical device
- 2. Support bracket

Figure 5: Bracket Pro Serie 25 WOB - FL with medical device

6. Operate the Bracket Pro Serie 25 WOB - FL

The contents in this section is intended for EMS and clinical personnel who are proficient, have received the required training and passed the skills assessment, therefore sufficiently knowledgeable to safely operate the support bracket.

6.1. Install the Bracket Pro Serie 25 WOB - FL in the Standard Surface Base

1. Align and insert the standard bottom disc horizontally in the Standard Surface Base (Figure 6), paying close attention not to wedge the tubing of the medical device.

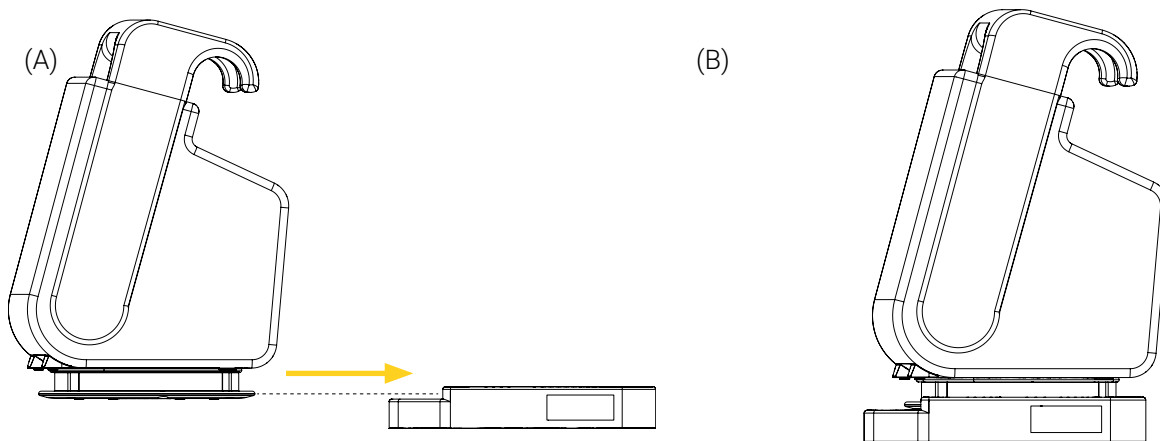

Figure 6: Installing the Bracket Pro Serie 25 WOB - FL in the Standard Surface Base

2. Ensure that the support bracket is secured. If the standard bottom disc stays in the Standard Surface Base after the verification, it is properly secured.
3. Turn the support bracket clockwise or counterclockwise (Figure 7), to the desired position when needed.

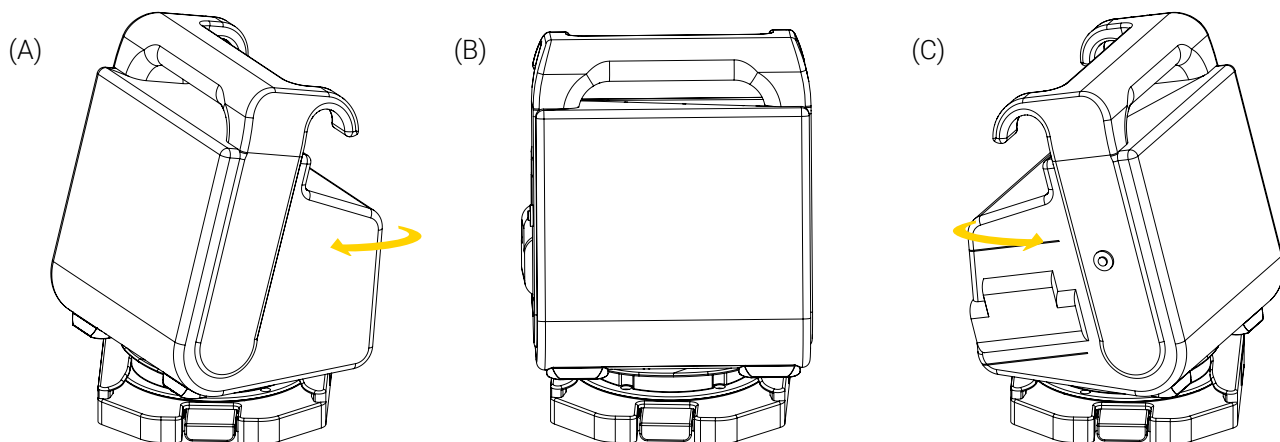

Figure 7: Operating the Bracket Pro Serie 25 WOB - FL

The installation of the Bracket Pro Serie 25 WOB - FL in the Standard Surface Base is complete.

6.2. Remove the Bracket Pro Serie 25 WOB - FL from the Standard Surface Base

Press and hold the quick release button of the Standard Surface Base, then slide the standard bottom disc forward horizontally out of the base (Figure 8).

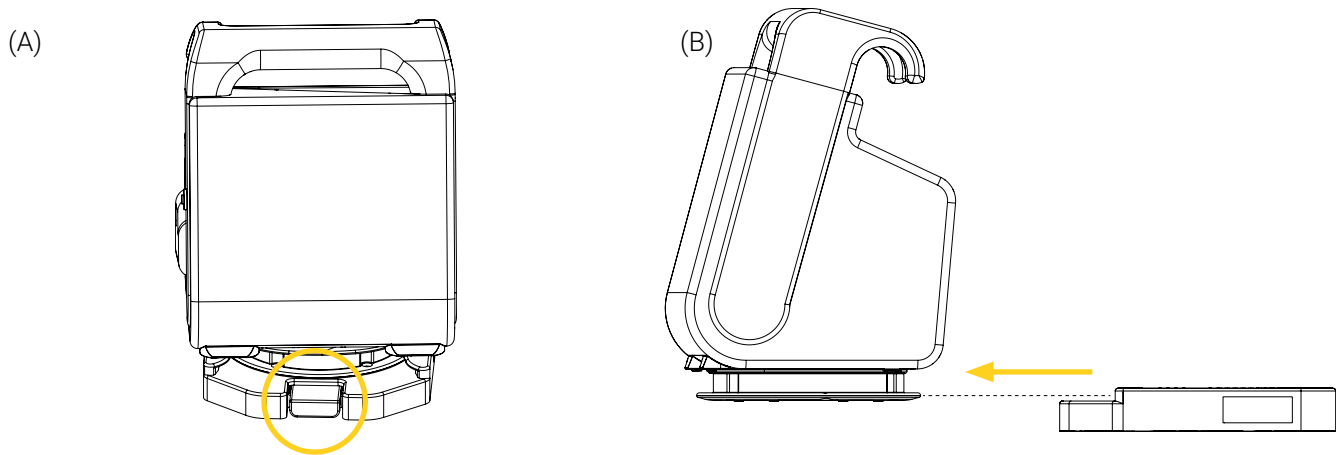

Figure 8: Removing the Bracket Pro Serie 25 WOB - FL from the Standard Surface Base

The removal of the Bracket Pro Serie 25 WOB - FL from the Standard Surface Base is complete.

Annex I EMS and clinical personnel Skills Assessment

Following training, a skills assessment should be given to each member of the EMS and clinical personnel to ensure they have fully comprehended the labelling, warnings and cautions, potential risks, safe practices and proper operating procedures needed to safely and effectively use the support bracket. Consider adding the following to your internal training protocols.

Trainee name: _____ Unit: _____

Assessor name: _____ Date: _____

EMS AND CLINICAL PERSONNEL SKILLS ASSESSMENT

SKILL CRITERIA	PASSED	FAILED
----------------	--------	--------

Labelling

Able to identify meaning and potential risks associated with the different safety labels:

- Safe Working Load (SWL).

Safety Measures

- Knows not to use the Bracket Pro Serie 25 WOB - FL if the screws located under the support bracket are loose or missing.
- Knows to ensure that the medical device is secured in the support bracket before it is moved.
- Knows not to overload the support bracket.

Operation

- Able to install/remove the support bracket in/from the Standard Surface Base.
- Able to operate the support bracket.
- Has practiced safely operating the support bracket, has perfected the manipulations and has acquired the required skill level to safely use with patient.



Annex II Unpack the Bracket Pro Serie 25 WOB - FL

Unpacking should be reserved for biomedical technicians (or equivalent) who have extensive mechanical experience, and advanced skill level.

1. Inspect the shipping box(es) for signs of damage before accepting shipment. Take pictures and report them promptly when applicable.
2. Move the shipping box(es) to the location of the installation.
3. Open the shipping box(es).
4. Unpack the box(es) and ensure that all shipping and packaging materials have been properly removed, prior to installation.

NOTE : Keep all packaging material for future use.

5. Identify all the components and hardware included for the installation when applicable, then set aside. Refer to Annex III on page 23 for the required parts.
6. Inspect the items for signs of damage. Take pictures and report them promptly when applicable.



Annex III Prepare the support bracket

The contents in this section is intended for biomedical technicians (or equivalent) who have extensive mechanical experience, and advanced skill level and have read the « Safety Measures » on page 11.

Required Installation Time

10 minutes

Required Tools

- Phillips-head screwdriver
- Medium strength thread lock adhesive (herein illustrated as )

Required Parts

Identify the required parts for the installation of the Bracket Pro Serie 25 WOB - FL (Figure 9).

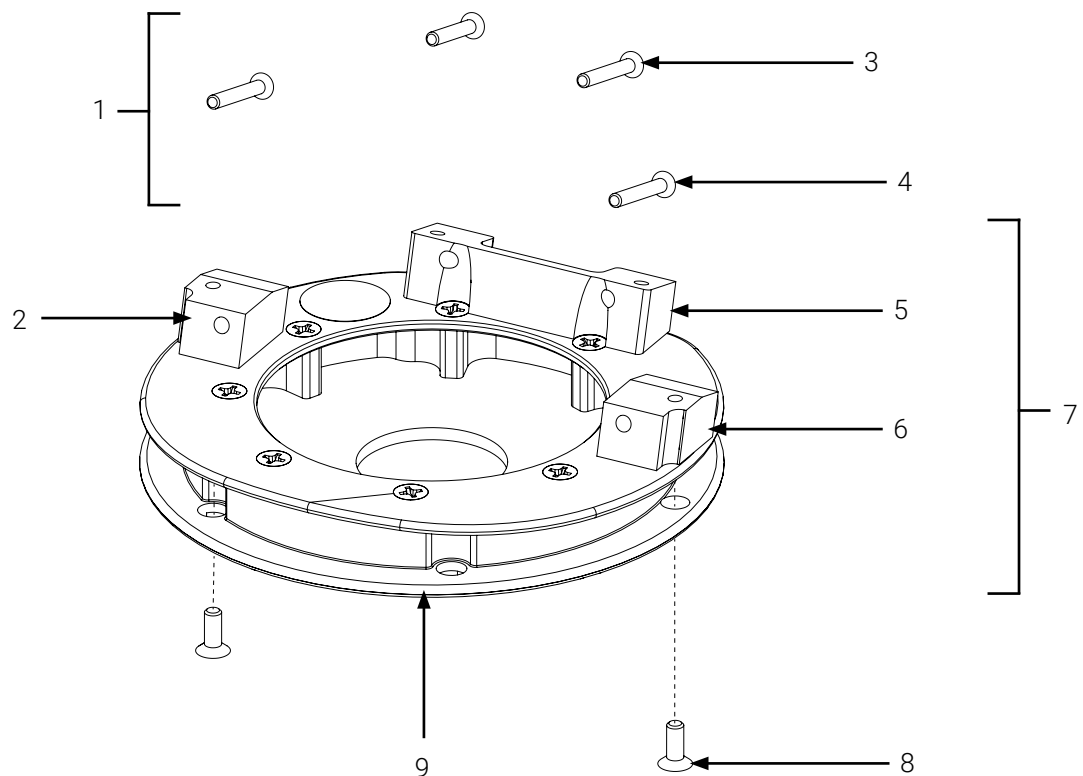

- | | |
|---|---|
| 1. Hardware bag content (4 screws) | 5. Rear mounting block |
| 2. Left mounting block | 6. Right mounting block |
| 3. M4 X 25 mm x 0.7 mm flat head
Phillips screw (2X) | 7. Bracket Pro Serie 25 WOB - FL |
| 4. M4 X 30 mm x 0.7 mm flat head
Phillips screw (2X) | 8. 10-32 x 1/2 in. flat head screws
(2X) |
| | 9. Standard bottom disc |

Figure 9: Bracket Pro Serie 25 WOB - FL assembly parts

Install the ZOLL X Series monitor/defibrillator on the Bracket Pro Serie 25 WOB - FL

1. Locate, then remove the two (2) blocks located under the medical device using a Phillips screwdriver. Refer to the manufacturer's user documentation for the safety guidelines and safe use of the medical device if needed, then store the blocks and screws following your internal protocol. The blocks will not be reused in this installation.
2. Flip the support bracket to have better access to the screw heads holding the mounting blocks (Figure 10 A).
3. Remove the left and right mounting blocks on either sides of the support bracket using a Phillips screwdriver (Figure 10 B). Set aside the mounting blocks and 10-32 x 1/2 in. flat head screws aside temporarily.

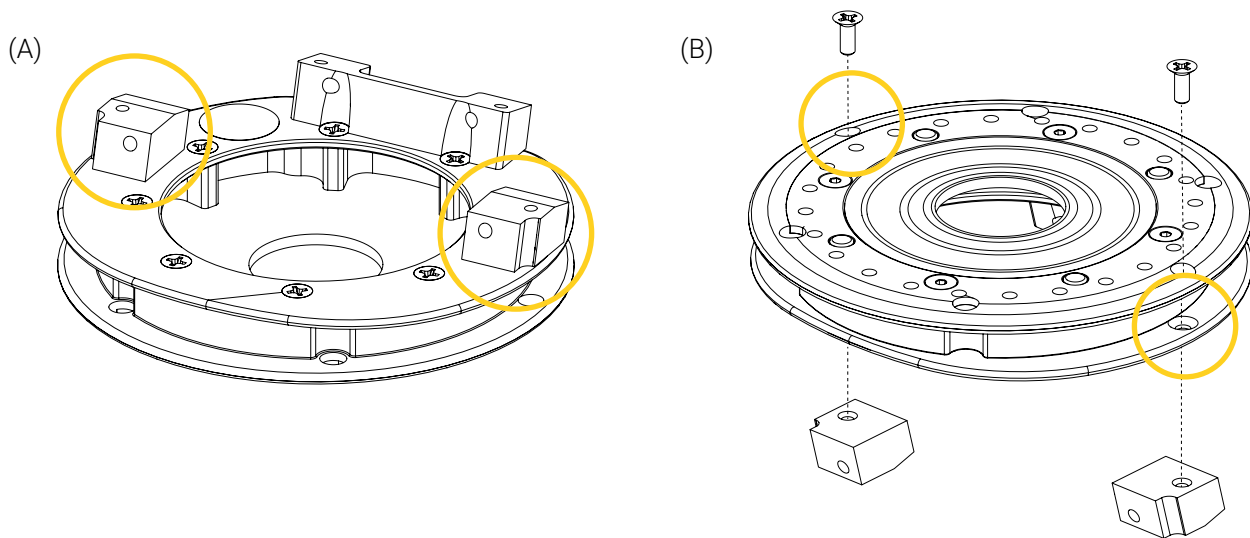
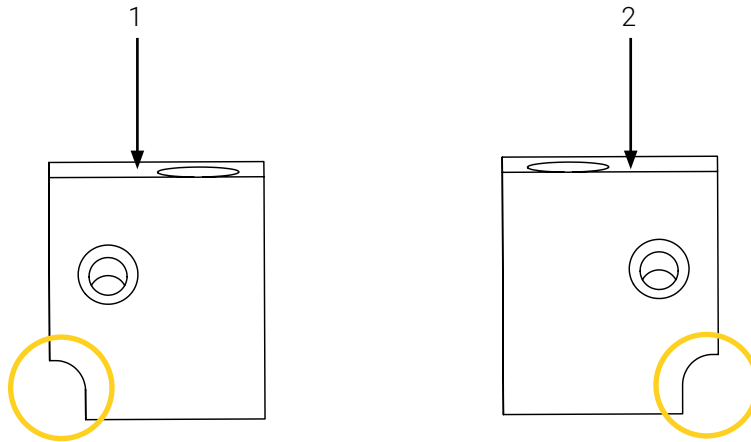

Figure 10: Removing the left and right mounting blocks on either sides of the support bracket

4. Identify the left and right mounting blocks to ensure that they are installed in the correct orientation and on the correct side of the medical device (Figure 11). In the correct orientation, the notch on each mounting block is installed on the outside of the support bracket.



1. Left mounting block

2. Right mounting block

Figure 11: Identifying the left and right mounting blocks

5. Install the left and right mounting blocks under the medical device using two (2) M4 X 30 mm x 0.7 mm flat head Phillips screws, thread lock adhesive and a Phillips screwdriver (Figure 12).

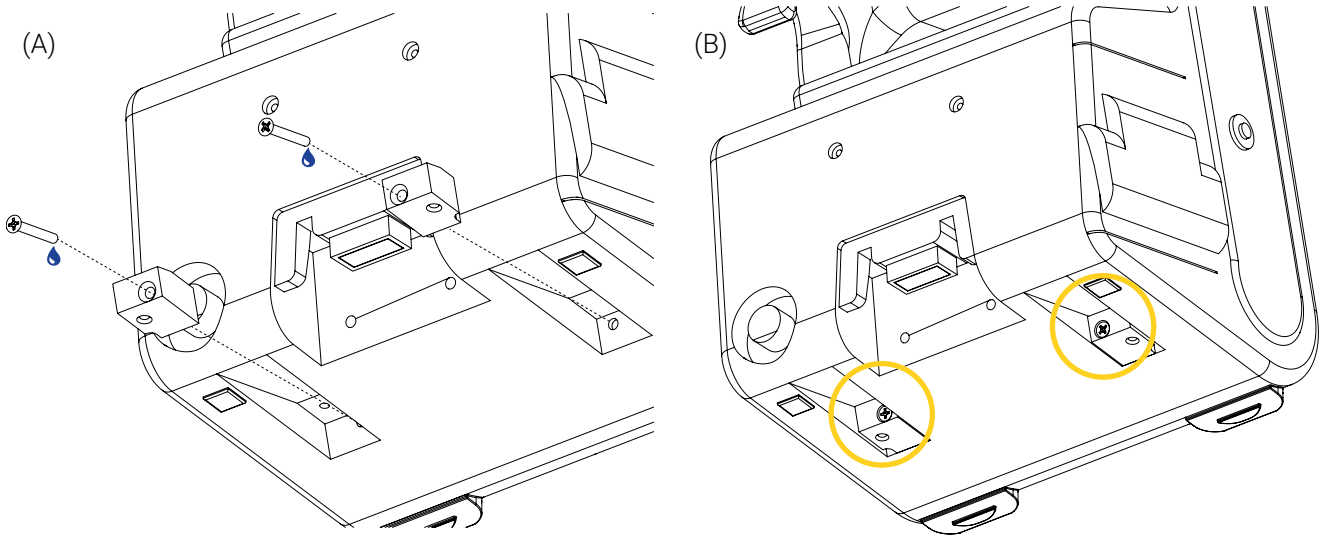

Figure 12: Installing the left and right mounting blocks under the medical device

- Align and install the medical device vertically on the support bracket (Figure 13 A) using the two (2) 10-32 x 1/2 in. flat head screws that were set aside in step 3, thread lock adhesive and a Phillips screwdriver.

NOTE : In the correct orientation, the rear mounting block on the support bracket will fit in the groove located at the back of the medical device (Figure 13 B).

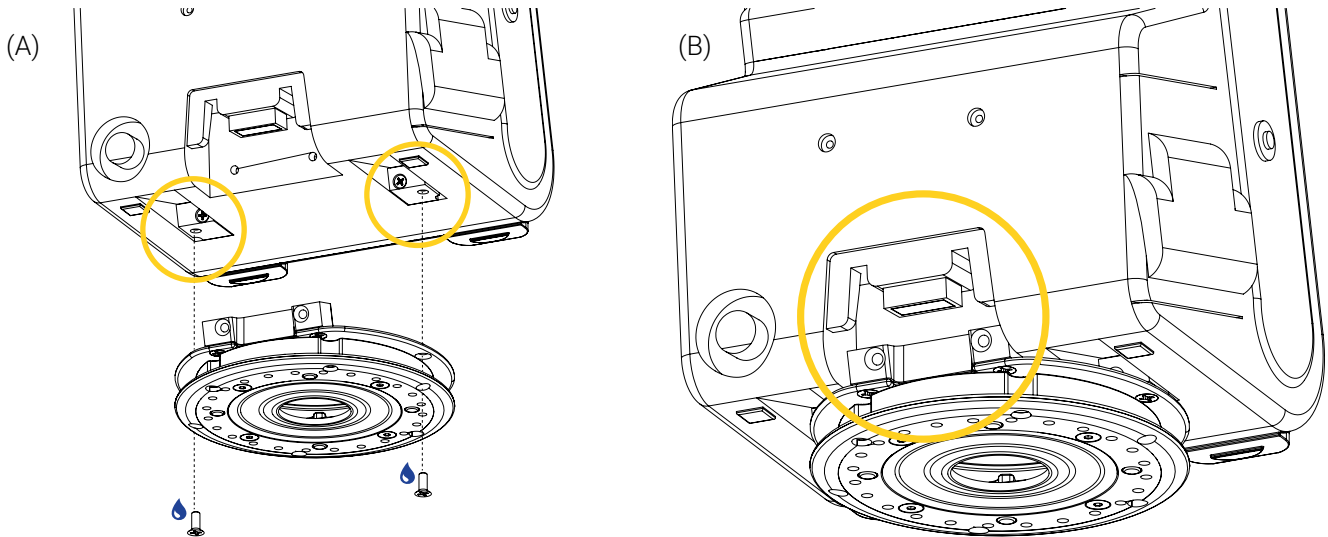

Figure 13: Installing the medical device on the support bracket

- Insert the two (2) M4 X 25 mm x 0.7 mm flat head Phillips screws in the screw holes of the rear mounting block, then tighten using thread lock adhesive and a Phillips screwdriver (Figure 14).

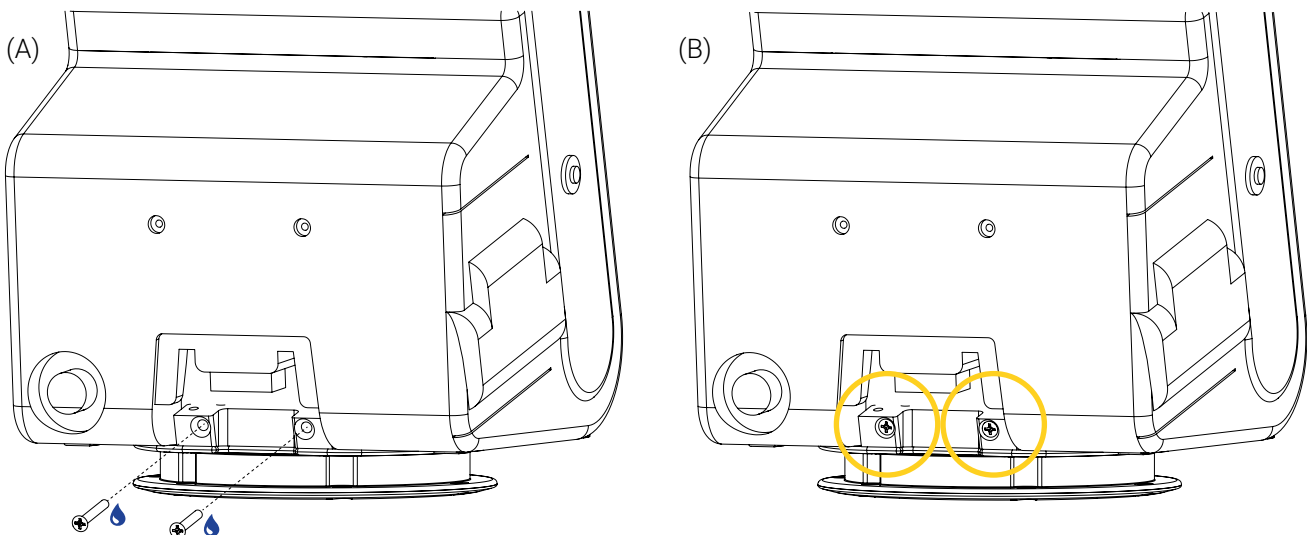

Figure 14: Securing the medical device on the support bracket

8. Ensure that the medical device is properly secured in the support bracket. It is properly secured if it does not move.

The installation of the medical device on the Bracket Pro Serie 25 WOB - FL is complete (Figure 15).

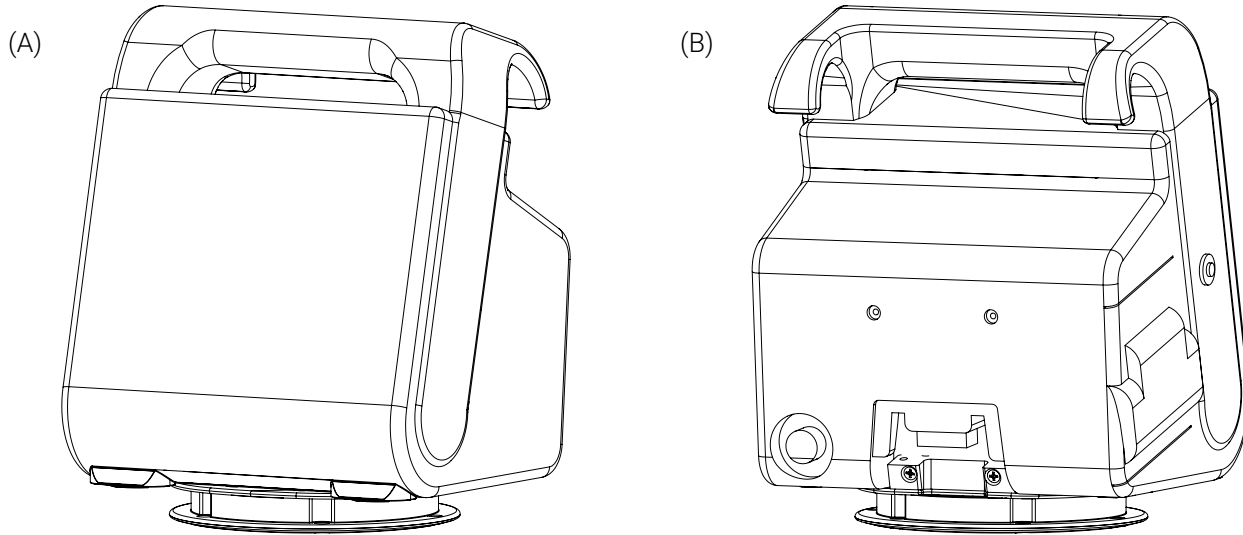

Figure 15: Medical device installed on the support bracket



Annex IV Maintenance

Safety checks and condition-based maintenance should be carried out by biomedical technicians (or equivalent) who have extensive mechanical experience, and advanced skill level and have read all the « Safety Measures » on page 11, and the maintenance specific safety measures listed below.

Factors such as weather, environment, geographical location and individual usage will necessitate different needs. For the maintenance of the Bracket Pro Serie 25 WOB - FL, follow the guidelines listed herein and in accordance with your service's current maintenance practices and protocols. Please contact Technical Support at techsupport@technimount.com for replacement parts or repair related issues, if needed.



WARNING – General Warning

- **Do not** perform safety checks or condition-based maintenance before having read the entire content of the user manual, gained in-depth knowledge and product comprehension, and familiarized yourself with the standards and guidelines.
- Safety checks and a condition-based maintenance plan are required and should be established for all Technimount products.
- Perform the safety checks and maintenance operations as described herein. Failing to follow the recommended maintenance plan or its guidelines could cause premature damage to the product.
- Use only Technimount parts, maintenance procedures, cleaning solutions and lubricants, as described herein. Using unapproved modified parts or procedures for the maintenance of the Technimount product may cause the system to be unstable and could cause injury to the patients or EMS and clinical personnel and void the product warranty.
- Replace damaged or worn-out parts if past their expected service life or when damaged (refer to « Annex V Replacement Parts/Kits » on page 35). Recycle damaged parts or dispose according to the environmental laws that apply to your jurisdiction and consult the Safety Data Sheets (SDS).



CAUTION – Safe Handling and Operation

- **Do not** use powered tools to screw the hardware during installation, as there is a potential risk of damage to the threads.
- **Do not** steam clean or use ultrasonic cleaners on the system or any of its components.
- **Do not** immerse the metal parts/components in water.
- To spot clean, the maximum water temperature should not exceed 180° F/82° C. The maximum water pressure should not exceed 1500 psi/103.5 BAR. If using a high pressure washer, the pressure nozzle must be kept a minimum of 24 in. (61 cm) from the unit.
- When cleaning, always use appropriate Personal Protection Equipment (PPE) based on established protocols (e.g., gloves, eyewear, etc.).



CAUTION – Corrosion

- Always rinse and dry the support bracket properly after using cleaning products. Certain types of cleaners may leave a corrosive residue on the surface of the product and could cause the premature corrosion of critical components. Refer to the product Safety Data Sheets (SDS) for chemical information or handling, storage and emergency measures in case of accident.
- Dispose of corrosive wastes according to the environmental laws that apply to your jurisdiction and consult the Safety Data Sheets (SDS).

**CAUTION – Follow Instructions for Use**

Always read and abide by all the safety guidelines identified, as well as follow instructions provided by the manufacturer of the cleaning product.

Maintenance Frequency

- Safety checks and the condition-based maintenance should be performed minimally every month or as frequently needed, to prolong the longevity of the support bracket in optimal conditions.
- Decontaminate the support bracket as recommended in your internal protocols, as well as the regulations and standards in virtue of the infection prevention and control procedures.

Required Tools

- Clean dry cloths
- Soft brush
- Pressure washer
- Cleaning solutions
- Medium strength thread lock adhesive (🔹)

Tested Cleaning Solutions

- Oxivir, 5% Hydrogen Peroxide with Peracetic Acid (AHP)
- Lavo 12, 10 000 ppm Sodium Hypochlorite
- TNT-100, 5% Quaternary Ammonium Compound
- Spectro-Sept, 5% Ethyl Alcohol
- Spectrol, 5% EDTA salt

Maintenance Plan

NOTE : In case of a non-conformity, stop using the product and contact Technical Support at techsupport@technimount.com immediately for a remedial action plan.

NOTE : Always keep records of your maintenance activities and immediately remove defective or expired products from your inventory.

MAINTENANCE PLAN	COMPLIANT	
SAFETY CHECKS	YES	NO

Bracket Pro Serie 25 WOB - FL (Figure 16)

- Visually inspect all the components of the support bracket and standard bottom disc to ensure there is no damage or chemical attack, that the hardware is in good condition and there are no loose screws:

<input type="checkbox"/>	<input type="checkbox"/>
--------------------------	--------------------------

 - If there is damage to the components or standard bottom disc, remove the product from circulation and contact Technical Support immediately for a remedial action plan.
 - If there are traces of chemical attack, follow the conditioned-based maintenance herein.
 - If the hardware is not in good condition, replace it. Contact Technical Support if needed.
 - If the hardware is loose, apply medium strength thread lock adhesive and tighten using a Phillips screwdriver.
- Visually inspect all the components of the support bracket and rim of the standard bottom disc to ensure there is no lodged particles. If so, immediately remove using a clean dry cloth.

<input type="checkbox"/>	<input type="checkbox"/>
--------------------------	--------------------------
- Insert/remove the standard bottom disc in/from the Standard Surface Base a few times to ensure proper functioning of the locking mechanism. The disc of the support bracket should be easily inserted and locked in position after the click sound and easily removed when using the quick release button.

<input type="checkbox"/>	<input type="checkbox"/>
--------------------------	--------------------------

CONDITION-BASED MAINTENANCE	YES	NO
Following the safety checks,		
Clean the Bracket Pro Serie 25 WOB - FL	<input type="checkbox"/>	<input type="checkbox"/>
1. Remove the excess dirt using a clean cloth, if needed.		
2. Remove the contaminants using a pressure washer or as recommended in your internal protocols and control procedures.		
3. Clean using a cloth and cleaning solution.		
4. Spot clean stains by applying the solution directly on the stain and let sit on the surface, if needed.		
<p>NOTE : Avoid over saturation and ensure that the product does not sit on the surface of the support bracket longer than recommended by the cleaner's manufacturer.</p>		
5. Thoroughly rinse the solution with a clean cloth dampened with lukewarm water, then dry all the components using a clean cloth before returning to service.		

Comments and observations following the Safety Checks and Condition-Based Maintenance:

Maintenance plan completed on (dd/mm/yyyy):

Maintenance plan completed by:

Illustrated Inspection Points

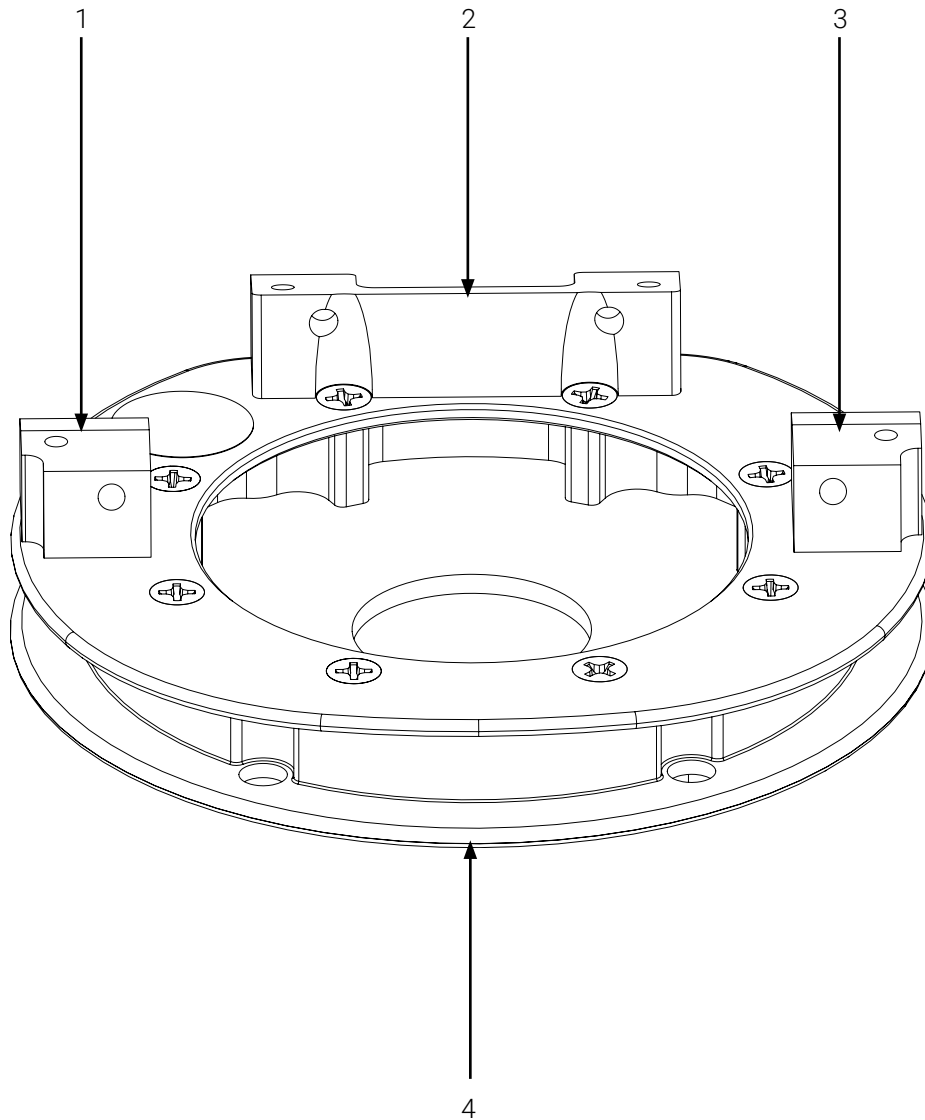

- | | |
|------------------------|-------------------------|
| 1. Left mounting block | 3. Right mounting block |
| 2. Rear mounting block | 4. Standard bottom disc |

Figure 16: Illustrated inspection points

Annex V Replacement Parts/Kits

Technimount reserves the right to change part numbers and products without notice. Please contact Customer Service at customerservice@technimount.com to ensure product options and availability, or Technical Support at techsupport@technimount.com for replacement parts/kits or repair related issues.

PART/KIT NUMBER	PART/KIT DESCRIPTION
951-00-XZ	Bracket Pro Serie 25 WOB - FL installation kit (4 screws)



TECHNIMOUNT

EMS®

Technimount EMS offers mounting solutions that can be installed on ambulance counters, walls and stretchers which allows for the equipment to follow the patient throughout the continuum of care. Our unparalleled level of flexibility allows for maximum operability in EMS, hospital and military environments.

Technimount EMS is driven to offer innovative solutions that respond to the unique device management needs of emergency and Critical Care Transport (CCT) teams for ground and air ambulances. Safety is at the core of our values, all Technimount systems are tested in compliance with the highest industry standards for impact resistance. Technimount EMS is committed to developing innovative solutions as healthcare practices evolve.

TECHNIMOUNT E.M.S. HOLDING INC.

3770 Jean Marchand Street, Suite 100-C
Quebec (Quebec) G2C 1Y6
Canada
T + 1 581 700-6613
TF + 1 888 639-2758 (North America)

technimount.com