

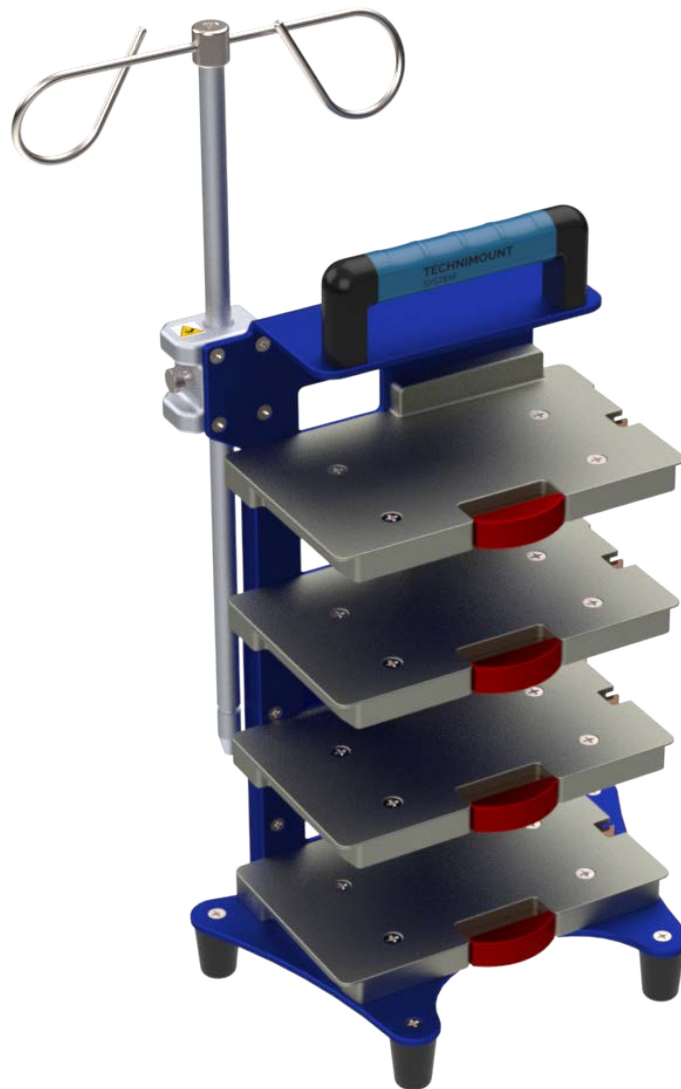

TECHNIMOUNT
EMS®

BRACKET PRO SERIE® 80 - FL4

USER MANUAL



SAFETY AND FLEXIBILITY
WHERE IT MATTERS MOST

Copyrights

Copyright 2025 Technimount E.M.S. Holding Inc. is an affiliated company of Technologies CGC Inc. All Rights Reserved. No part of this publication may be reproduced, transmitted, transcribed, backed-up on a retrieval system, translated in any language, modified in any form or by any means, without the written permission of Technimount or its affiliate companies.

Trademarks

Product and medical devices manufacturer names are Trademarks™ or Registered Trademarks® of their respective holders.

- Technimount EMS® and Bracket Pro Serie® are registered trademarks of Technologies CGC Inc.
- B-Braun®, Infusomat® Space® and Perfusor® Space® are registered trademarks of B-Braun.
- Oxivir® is a registered trademark of Diversey.
- Lavo® is a registered trademark of KIK Holdco Company, Inc.

For any issues with your Technimount product, its components, or for any technical questions during the installation, operation, or maintenance, please contact Technical Support at techsupport@technimount.com.

Contact Information

Technimount E.M.S. Holding Inc.

C/O: Regulatory Affairs

3770 Jean Marchand Street, Suite 100-C

Quebec (Quebec) G2C 1Y6

Canada

customerservice@technimount.com

techsupport@technimount.com

legal@technimount.com

www.technimount.com

T + 1 581 700-6613

TF + 1 888 639-2758 (North America)

Table of Contents

Copyrights	ii
Trademarks	ii
Contact Information	ii
1. General Mentions and Considerations	5
..... 1.1. Intended Use	5
..... 1.2. User Competency	5
..... 1.3. Warranties	6
..... 1.3.1. Warranty Policy	6
..... 1.3.2. Limited Warranty	6
..... 1.3.3. International Warranty Clause	6
..... 1.3.4. User Liability	7
..... 1.4. Claims	7
..... 1.4.1. Damaged or Defective Merchandise	7
..... 1.4.2. Return Policy	7
..... 1.4.3. Return of Material Authorization (RMA)	8
..... 1.4.4. Claim Process	8
2. General Safety Guidelines	9
..... 2.1. Symbols and Definitions	9
..... 2.2. Labels	10
..... 2.3. Safety Measures	11
3. Technical Specifications	13
4. Bracket Pro Serie 80 - FL4 Orientation Diagrams	14
5. Bracket Pro Serie 80 - FL4 Illustrated Parts	16
6. Operate the Bracket Pro Serie 80 - FL4	18
..... 6.1. Install the Pump(s) in the Bracket Pro Serie 80 - FL4	18
..... 6.2. Remove the Pump(s) from the Bracket Pro Serie 80 - FL4	19
..... 6.3. Install the Bracket Pro Serie 80 - FL4 on the Micro Base	20
..... 6.4. Remove the Bracket Pro Serie 80 - FL4 from the Micro Base	22
..... 6.5. Operate the IV Pole	23
Annex I EMS and clinical personnel Skills Assessment	25
Annex II Unpack the Bracket Pro Serie 80 - FL4	27
Annex III Prepare the support bracket	29

..... Install the IV Pole in the IV Pole Holder	29
Annex IV Maintenance.....	31
..... Maintenance Frequency.....	32
..... Required Tools	32
..... Tested Cleaning Solutions	32
..... Maintenance Plan.....	33
..... Illustrated Inspection Points.....	36
Annex V Replacement Parts/Kits	37

1. General Mentions and Considerations

The Bracket Pro Serie 80 - FL4 user manual includes detailed product information, standards and guidelines to assist the administrator/manager/supervisor and biomedical technician (or equivalent) with the unpacking, assembling (when indicated) and maintenance of the Technimount product. It also includes specific user-related information to assist trained EMS and clinical personnel with effectively operating the support bracket.

Please read the user manual thoroughly to fully assess, comprehend, then relay its content to EMS and clinical personnel during training, to warn them of any potential danger of its abuse, how to safely use the product and provide a safe environment for patients as well as themselves. Your existing protocols should be updated to include the Technimount product(s) standards, guidelines, requirements and safety recommendations included within this documentation. The user manual should remain available to users when needed and relayed if the product is subsequently sold.

NOTE : Technimount continually seeks advancements in product design and quality. While the user manual contains the most updated product information available at the time of printing, it may contain minor differences from the current version, including image references. For more information, please contact Technical Support at techsupport@technimount.com.

NOTE : Technimount reserves the right to change part numbers and products without notice. Please contact Customer Service at customerservice@technimount.com to ensure product options and availability.

1.1. Intended Use

The Bracket Pro Serie 80 - FL4 is designed to aid trained EMS and clinical personnel move the B-Braun Infusomat Space volumetric infusion pumps and Perfusor Space syringe pumps that are essential to patient care during EMS and critical care transport.

1.2. User Competency

To safely operate the support bracket, EMS and clinical personnel must have the required skill level. Training should be given to EMS and clinical personnel, taking in account the skill level that is necessary to comply with their function and level of interaction with the Bracket Pro Serie 80 - FL4:

- **Proficient (trained EMS and clinical personnel):** Has received the required training, is sufficiently knowledgeable to safely operate the product and have passed the skills assessment (refer to « Annex I EMS and clinical personnel Skills Assessment » on page 25).

NOTE : Any member of the EMS and clinical personnel who has not received the required training and lacks the knowledge needed to safely operate the support bracket must not use the product.

- **Expert (administrator/manager/supervisor):** Has in-depth knowledge and product comprehension, and is familiar with standards and guidelines. Skilled to train EMS and clinical personnel on how to safely use the product.
- **Advanced (biomedical technician or equivalent):** Has extensive mechanical experience. Skilled to perform the unpacking, assembly, safety checks and condition-based maintenance procedures as detailed in « Annex IV Maintenance » on page 31, basic troubleshooting, upgrade procedures and replacement procedures.

1.3. Warranties

1.3.1. Warranty Policy

This statement constitutes Technimount's entire warranty policy with regards to Technimount products. Technimount makes no other warranty or representation, neither expressed nor implied, except as stated herein. There is no warranty of merchantability or warranty of fitness for any particular purpose. Under no circumstances will Technimount be held liable hereunder for incidental or consequential damages, arising from or in any manner, related to sales or use of any such product.

Technimount E.M.S. Holding Inc. guarantees to the original "Purchaser" of the "Product" with which this "Limited warranty" is included, that the product will be free from "Defects" in workmanship and materials under normal use for a "Warranty period" of one (1) year from the product purchase date by the purchaser. During the warranty period, the product will be repaired or replaced according to the "Limited warranty" without charge to the purchaser for parts or labor. The parts and product may be repaired or replaced with new or refurbished parts or products. Herein this Limited Warranty, "Refurbished" means parts and products which have been returned to the factory, specifically. If the product is repaired or replaced within the warranty period, the greater of the remaining warranty period will apply, or three (3) months from the date of repair or replacement. If the product is repaired or replaced after the warranty period has expired, the warranty period for the repair or replacement will expire three (3) months after the repair or replacement date.

1.3.2. Limited Warranty

Technimount products are intended to retain medical devices in place in the case of a single emergency landing or a single crash impact. Technimount products must not be reused if involved in a single emergency landing or a single crash impact and must thereafter be replaced. If the end user uses a Technimount product following a single emergency landing or a single crash impact, it is at the end user's own risk and Technimount will not be held liable.

The limited warranty does not apply to normal wear that could result from normal use. It does not apply when the product or any of its components have been disassembled or repaired by someone not authorized by "Technimount". It does not cover repair or the replacement of any product or part thereof damaged by neglect, misuse, moisture, liquids, exposure to heat, accidents, abuse, and non-compliance with the instructions for installation and use provided with the product. It does not cover physical damage to the surface of the product. The decision to repair, replace or refuse the coverage is final and at the sole discretion of Technimount, without any compensation or obligation from Technimount. The product defined as a "support bracket" or "bracket" is specifically designed to fill this requirement. Any other use will void the warranty and Technimount shall not be held liable on any claim if the product has been modified or adapted for use.

1.3.3. International Warranty Clause

This warranty abides by the Canadian domestic policy. Warranty outside Canada may vary by country. Please contact Customer Service at customerservice@technimount.com for more information.

1.3.4. User Liability

The purchaser and administrator are responsible to validate regulations and standards for safety in their region, to comply with applicable safety regulations. Technimount is not responsible to inform the purchaser or the administrator of any applicable legislation for safety in their area.

The administrator is responsible for providing proper training to any personnel who will install, operate and perform maintenance on Technimount products.

1.4. Claims

1.4.1. Damaged or Defective Merchandise

ICC Regulations require that claims for damaged merchandise must be made with the carrier within fifteen (15) days of the reception date. **Do not** accept damaged merchandise unless such damage is noted on the delivery receipt at the time of reception. Upon prompt notification, Technimount will file a freight claim with the appropriate carrier for damages incurred. Claims are limited in amount to the actual replacement cost. If the claim has not been received by Technimount within the fifteen (15) day period following the date of delivery, or the damage was not noted on the delivery receipt at the time of receipt, the customer will be responsible for the full payment of the original invoice.

Claims for any short or broken merchandise must be made within thirty (30) days of invoicing. For details, refer to the claim process or contact Customer Service at customerservice@technimount.com.

1.4.2. Return Policy

Technimount products may be returned up to sixty (60) days from the reception date, if:

- The received product does not match what was originally ordered.
- The product does not meet the Technimount technical sheet specifications.
- The product is not compatible with the system on which it was intended to be installed on.

To return a Technimount product,

- A Return of Merchandise Authorized (RMA) must be requested and approved by Technimount prior to returning the product.
- Products must be returned undamaged and in its original packaging, appropriately identified with the approved RMA number. Returns will not be approved on a modified or damaged item.
- Charges may apply if the package received is damaged or items are missing.
- Purchaser is responsible for a restocking fee (refer to Table 1).

Table 1: Restocking fees

RESTOCKING FEES	
Prior to thirty (30) days	10%
Prior to forty-five (45) days	25%
Prior to sixty (60) days	30%

For any manufacturing defect, refer to the conditions within the warranty policy or contact Customer Service at customerservice@technimount.com for additional information.

1.4.3. Return of Material Authorization (RMA)

The Technimount Customer Service department is responsible for all merchandise returns and will provide a Return of Merchandise Authorization (RMA) number, upon approval. The RMA must be printed and placed on the returned merchandise. Technimount reserves the right to charge shipping and restocking fees (refer to Table 1) for the returned items. Special, modified, or discontinued items are not subject to returns.

1.4.4. Claim Process

Upon reception of the returned merchandise, a thorough inspection will be performed. If the merchandise is compliant with the return policy or it is found that the product is defective, Technimount will take corrective actions and close the claim. If, however, it is found that the product is not defective, but rather misused or abused, the product will not be covered by the warranty. Details of our findings and conclusions will be provided shortly thereafter. To submit a claim, contact Customer Service at customerservice@technimount.com to obtain a Return of Material Authorization (RMA) form and return instructions.

2. General Safety Guidelines

Always read and abide by all the safety guidelines identified within this document. Pictograms, safety symbols and labels are used to alert the user to a potentially hazardous situation, which, if not avoided, may result in minor or moderate injury to the patients or EMS and clinical personnel, or damage to the product. This includes the special care necessary for the safe and effective use of the Technimount product to avoid damage that may occur from use or misuse. The terms "Warning" and "Caution" herein carry special meaning and should be carefully reviewed.

WARNING – Indicates a hazardous situation that, if not avoided, could result in death or serious injury.

CAUTION – Indicates a hazardous situation that, if not avoided, could result in minor or moderate injury.

2.1. Symbols and Definitions



WARNING – Hand Crush/Pinch Point

Indicates an area where mechanical components could move toward each other and might result in a potential crush/pinch hazard.



WARNING – Do Not Step

Indicates an area where there is potential risk of tipping if the user steps, stands, sits or rests his/her foot that could result in serious injuries to the patients or EMS and clinical personnel, or damage to the product.



CAUTION – Safe Working Load (SWL)/Load Balance

Indicates the total maximum charge for a safe use of the product.



CAUTION – Safe Handling and Operation

Alerts the reader to pay special attention to the recommendations for safe use of the product, and of potentially hazardous situations that could result in minor injuries to the patients or EMS and clinical personnel. This includes the special care necessary for the safe and effective use of the product to avoid damage that may occur from use or misuse.



CAUTION – Safe Practice

Alerts the reader to pay special attention to the recommendations and methods outlining how to safely operate the product to minimize risks to the patients, EMS and clinical personnel and the product.



CAUTION – General Mandatory Action

Call for action. Alerts the reader to potential risk to the patients or EMS and clinical personnel not following the mandatory action specified by the supplementary sign.



CAUTION – Follow Instructions for Use

Call for action. Reminds the reader to consult the user manual for information.



CAUTION – Two (2) Person Lift

Heavy load. Alerts the reader to a two (2) person lift carrying technique recommendation based on the weight and/or size of the product.

2.2. Labels

Labelling on the surface of the Technimount product, quickly identify potential risks and provides information to the user. A safety label and a manufacturing label, including the serial number and safe working load (Figure 1), can be seen on the Technimount product.

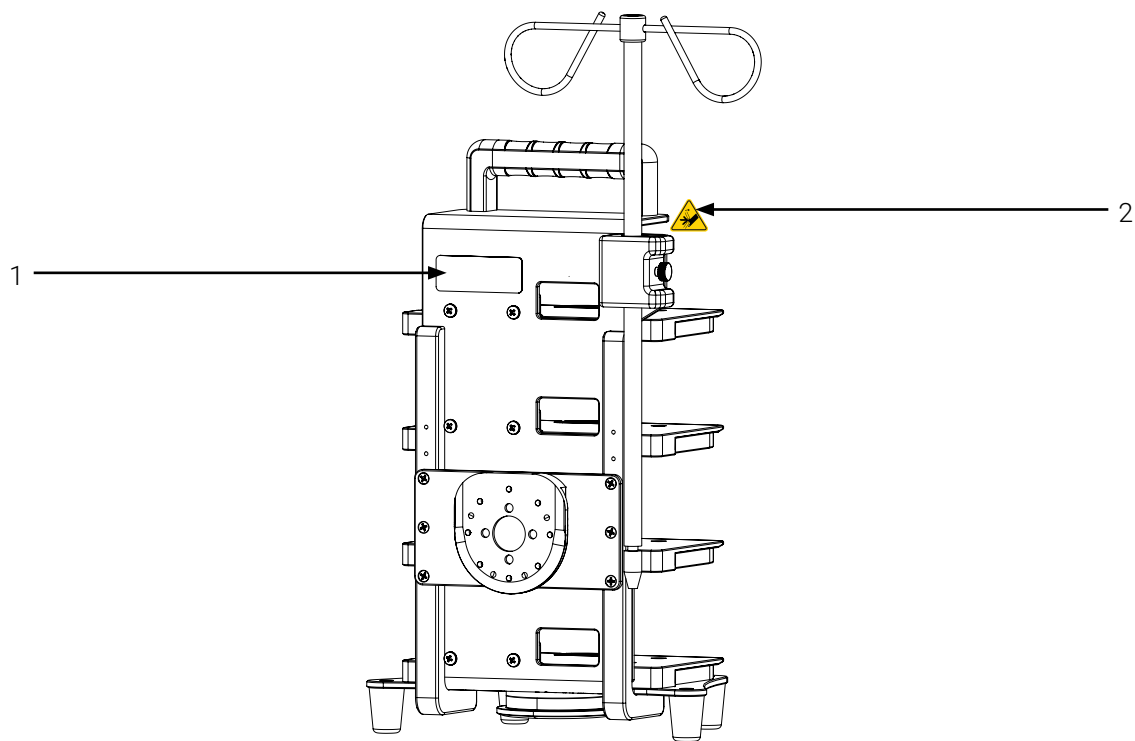

1. Manufacturing label

2. Hand Crush/Pinch point

Figure 1: Location of the safety and manufacturing labels

2.3. Safety Measures

Carefully read all the safety measures herein before operating the Technimount product, relay to EMS and clinical personnel during training, and include in your existing protocols.

More specific safety measures intended for biomedical technicians (or equivalent) relating to the safety checks and conditioned-based maintenance can be found in « Annex IV Maintenance » on page 31.



WARNING – Hand Crush/Pinch Point

Always ensure that the IV pole is secured in one (1) of the two (2) grooves to avoid it from falling in the IV pole holder or unwillingly removed from the holder, that could result in injury to the patients or EMS and clinical personnel.



WARNING – Risk of Injury

- Always use compatible mounting systems and medical devices when applicable, to avoid unpredictable functioning resulting injury to the patients or EMS and clinical personnel. Refer to the « Technical Specifications » on page 13 for compatibilities.
- Improper use of the Technimount product may damage it or cause injury to the patients or EMS and clinical personnel.
- If any serious incident occurs with the support bracket, immediately stop using the product, report this incident to Technical Support at technicalsupport@technimount.com and the applicable regulatory agency.



CAUTION – Safe Practice

- Always pay close attention to the condition of the safety mechanisms of the support bracket and the IV pole to avoid risks of damage, equipment falling, or injuries to the patients or EMS and clinical personnel.
- Practice safely operating the support bracket until the manipulations have been perfected, before use with patients. Improper use of a Technimount product may damage it or cause injury to the patients or EMS and clinical personnel.
- Regulations and standards for safety are the sole responsibility of the end user. Ensure that the installation specifications meet the local and regional compliance requirements before use.
- Refer to your protocols and the user documentation provided with the pumps for the safety guidelines and safe use.



CAUTION – Safe Handling and Operation

- Do not use the IV pole during transport and always ensure that the IV pole is lowered and secured in the IV pole holder.
- Always ensure that the medical devices and IV pole are properly secured in the support bracket before it is moved to avoid risks of damage, equipment falling, or injuries to the patients or EMS and clinical personnel.



CAUTION – Working Load (SWL)/Load Balance

- **Do not** overload the support bracket to avoid tipping incidents or risks of collapsing. The total Safe Working Load (SWL) is 14 lb (6.366 kg).

**CAUTION – Follow the Instruction for Use**

- Always read and abide by all the safety guidelines identified, as well as follow instructions provided within the user manual of the Technimount product.
- The Bracket Pro Serie 80 - FL4 is designed specifically to support the B-Braun Infusomat Space volumetric infusion pump and Perfusor Space Syringe Pump. Refer to the manufacturer's user documentation for the safety guidelines and safe use.

3. Technical Specifications

Product Name	Bracket Pro Serie® 80 - FL4
Description	Support bracket designed to aid trained EMS and clinical personnel move the B-Braun® Infusomat® Space volumetric infusion pumps and Perfusor® Space® syringe pumps during EMS and critical care transport
Product Code	1110-20-BBRK4-FL
Operating Environment	EMS/CCT (ground and air)
Compliance	Designed to comply with FAA, 14 CFR § 23, 25, 27 & 29 (applicable sections)
Expected Service Life	5 years
Compatible Stretcher	N/A
Compatible Mounting System	<ul style="list-style-type: none"> - Micro Base (horizontal) - Micro Base (vertical)
Compatible Medical Device	<ul style="list-style-type: none"> - B-Braun® Infusomat® Space volumetric infusion pump - B-Braun® Perfusor® Space® Syringe Pump
Dimensions (W X D X H)	12.7 in. X 7.8 in. X 20.5 in. (32.39 cm X 19.81 cm X 52.07 cm), including the IV pole, w/o pumps or accessories
Weight	11.85 lb (5.39 kg), including the IV pole, w/o pumps
Composition	<ul style="list-style-type: none"> - Bracket Pro Serie® 80 - FL4: aluminum, bronze, stainless steel, plastic - IV pole: aluminum, stainless steel - Micro disc and anti-rotation micro disc: aluminum
Total Safe Working Load (SWL)	14 lb (6.366 kg)
Operating Temperature	- 31° F to 113° F (- 35° C to 45° C)
Cleaning Solutions	<ul style="list-style-type: none"> - Oxivir®, 5% Hydrogen Peroxide with Peracetic Acid (AHP) - Lavo® 12, 10 000 ppm Sodium Hypochlorite - TNT-100, 5% Quaternary Ammonium Compound - Spectro-Sept, 5% Ethyl Alcohol - Spectrol, 5% EDTA salt
Options	N/A

4. Bracket Pro Serie 80 - FL4 Orientation Diagrams

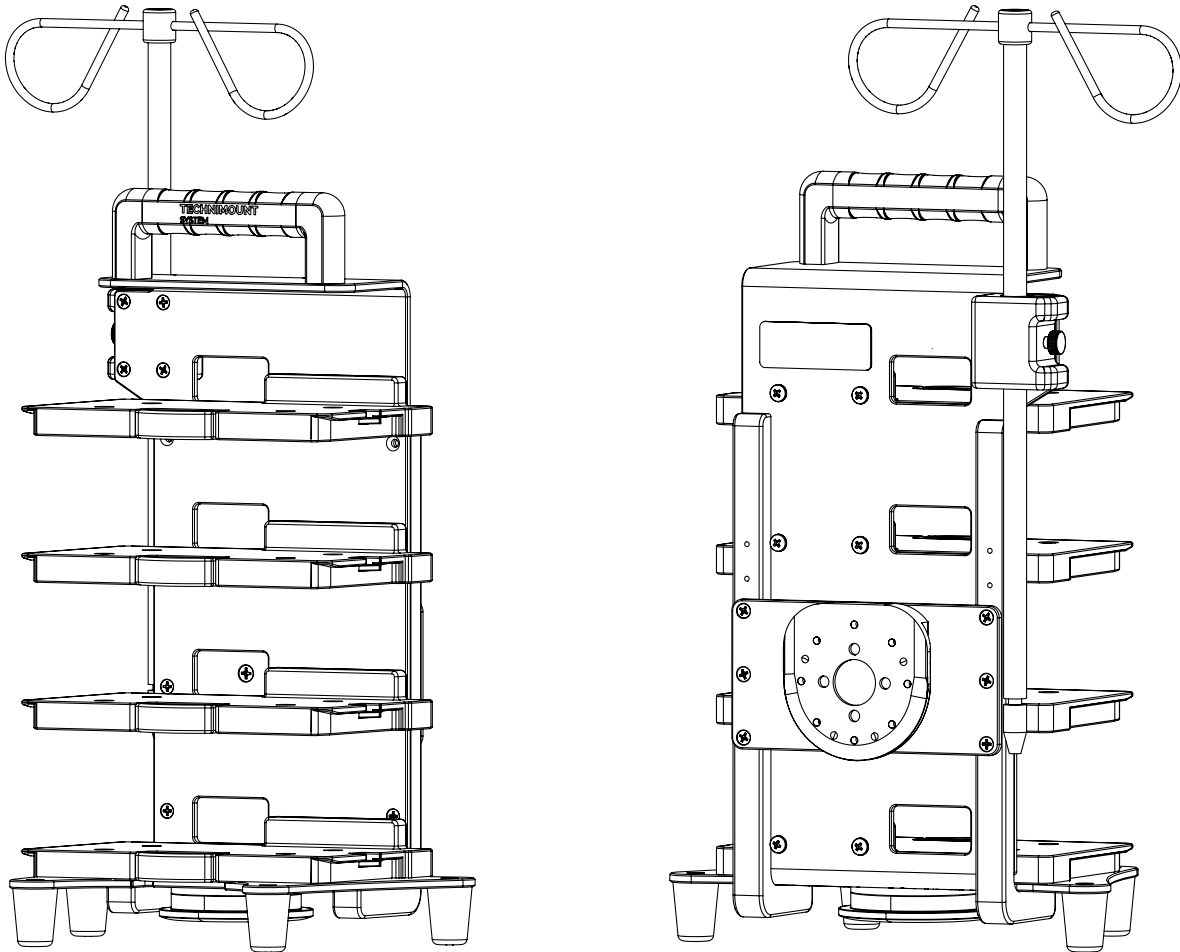

Front of the support bracket

Back of the support bracket

Figure 2: Bracket Pro Serie 80 - FL4 orientation diagram

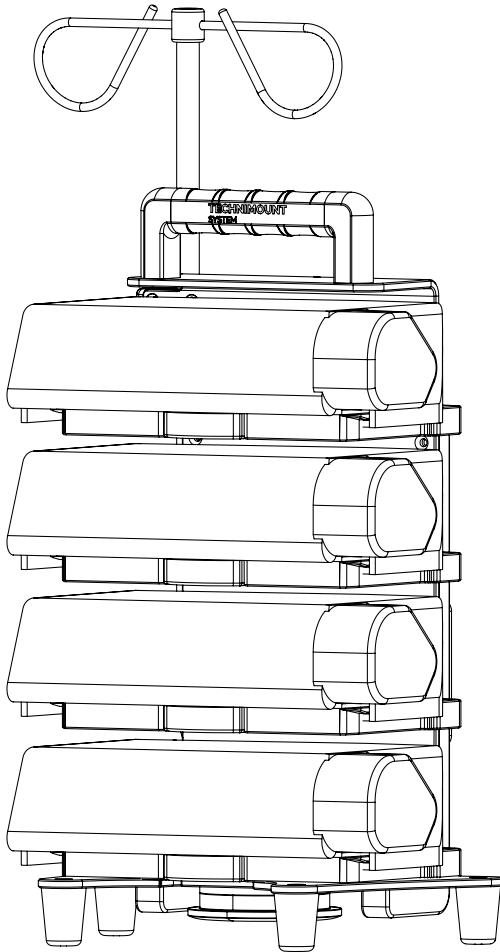

Front of the support bracket

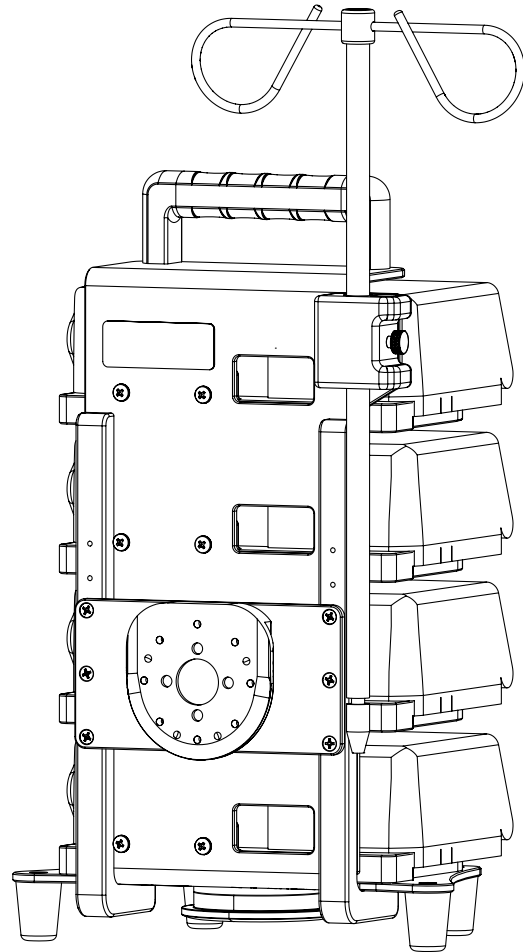

Back of the support bracket

Figure 3: Bracket Pro Serie 80 - FL4 orientation diagram with pump (Perfusor Space Syringe Pump illustrated)

5. Bracket Pro Serie 80 - FL4 Illustrated Parts

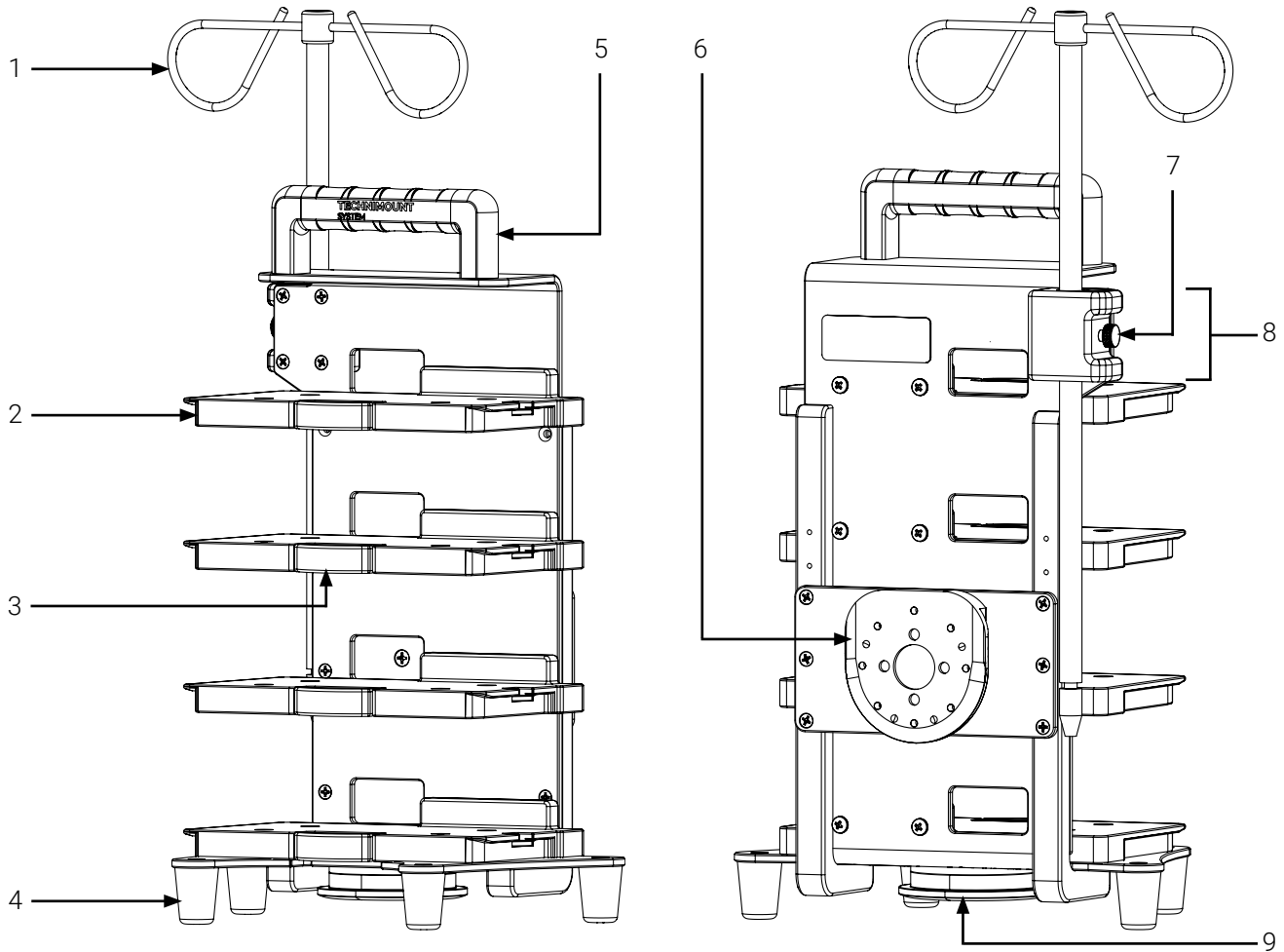

- | | |
|--|---|
| 1. IV pole | 6. Anti-rotation micro disc (vertical) |
| 2. Pump shelf (4X) | 7. Quick release knob/Height adjustment (IV pole) |
| 3. Quick release button (pump shelf; 4X) | 8. IV pole holder |
| 4. Feet (4X) | 9. Micro disc (horizontal) |
| 5. Handle | |

Figure 4: Bracket Pro Serie 80 - FL4 components

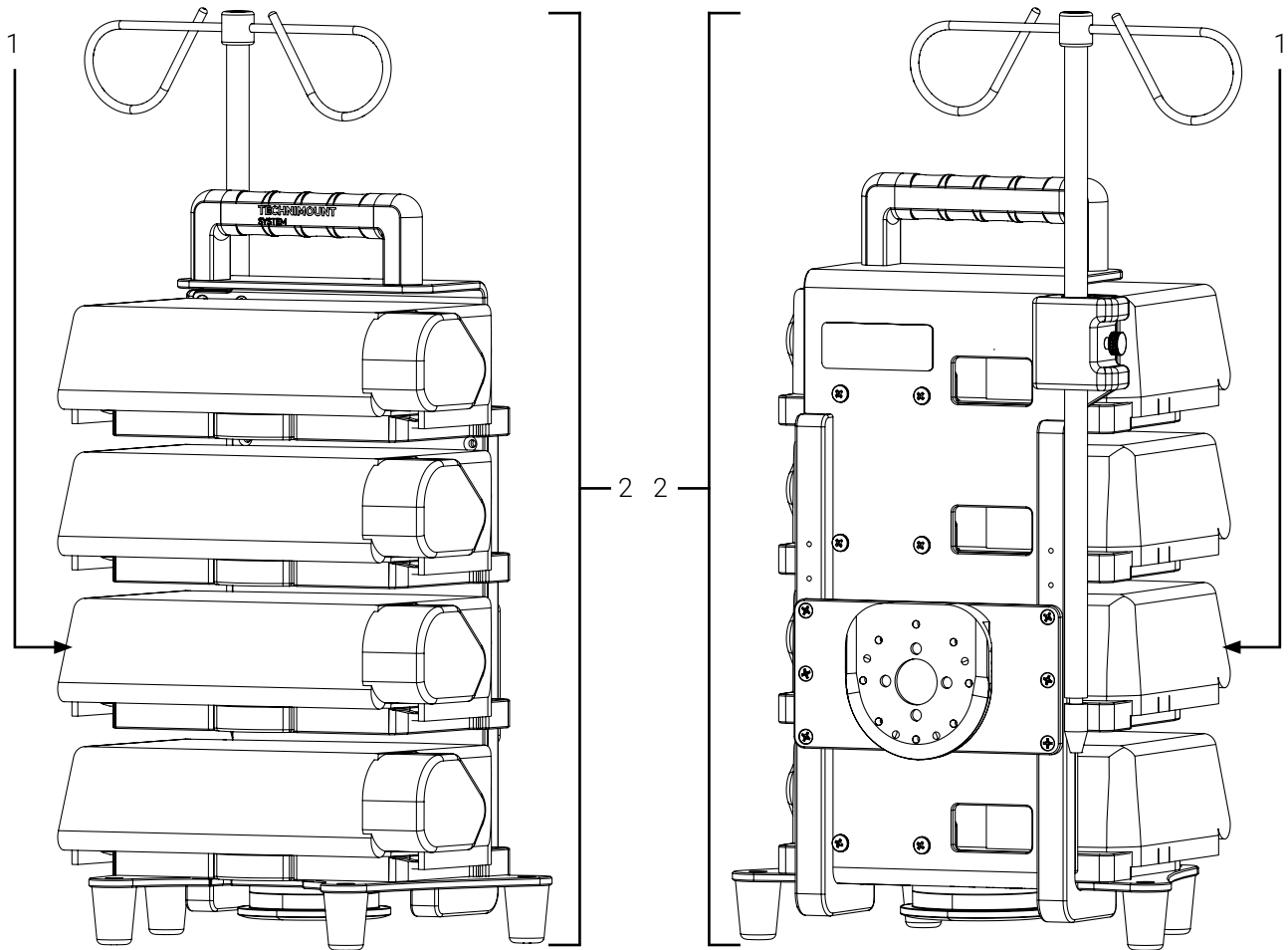

- 1. B-Braun pump (4X)
- 2. Bracket Pro Serie 80 - FL4

Figure 5: Bracket Pro Serie 80 - FL4 with pump (Perfusor Space Syringe Pump illustrated)

6. Operate the Bracket Pro Serie 80 - FL4

The contents in this section is intended for EMS and clinical personnel who are proficient, have received the required training and passed the skills assessment, therefore sufficiently knowledgeable to safely operate the support bracket.

NOTE : The following procedure is illustrated using a B-Braun Perfusor Space syringe pump, but the same instructions throughout the documentation applies for the B-Braun Infusomat Space volumetric infusion pumps model.

6.1. Install the Pump(s) in the Bracket Pro Serie 80 - FL4

1. Align the bottom grooves under the pump with the pump shelf of your choice, then push the pump until the safety mechanism of the shelf is activated (Figure 6).

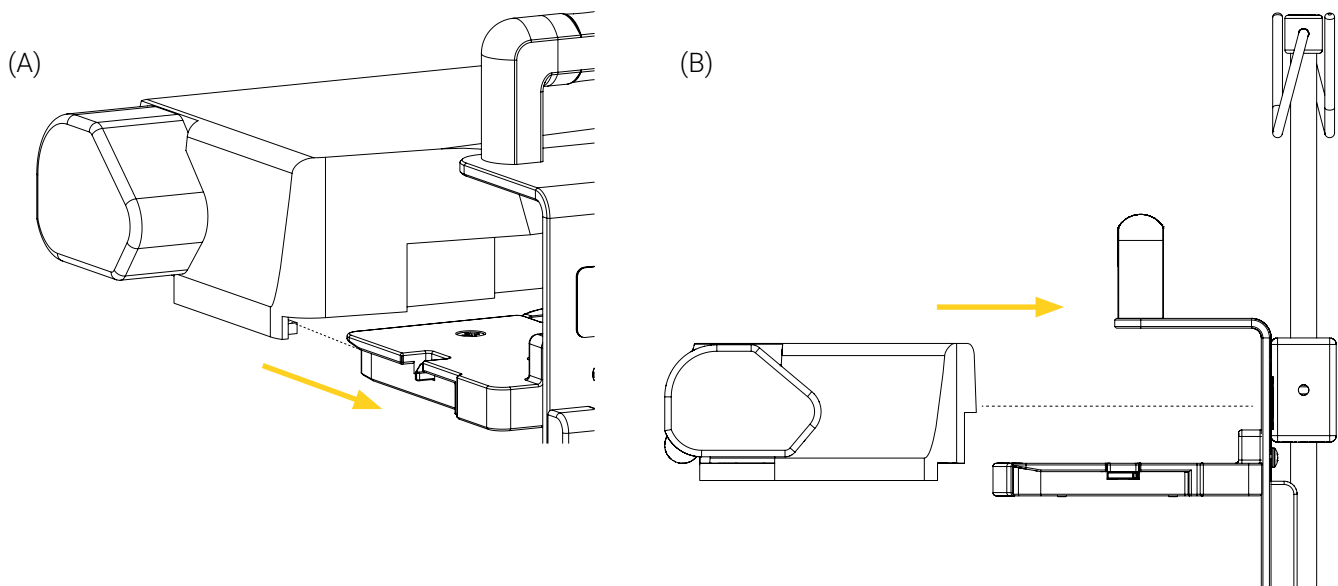

Figure 6: Installing the pump on the pump shelf

2. Ensure that the pump is secured. If the pump does not move and stays on the shelf after the verification, it is properly secured.
3. Plug the power cord in the pump. Refer to your protocols and the manufacturer's user documentation for the safety guidelines and safe use of the pump(s).

NOTE : To facilitate the connection, use of a B-Braun Combi Lead Cable (user provided). Refer to the manufacturer's user documentation for the safety guidelines and safe use of the pump(s) and the compatible accessories.

- Repeat steps 1 to 3 for the installation of up to four (4) pumps (Figure 7) if needed.

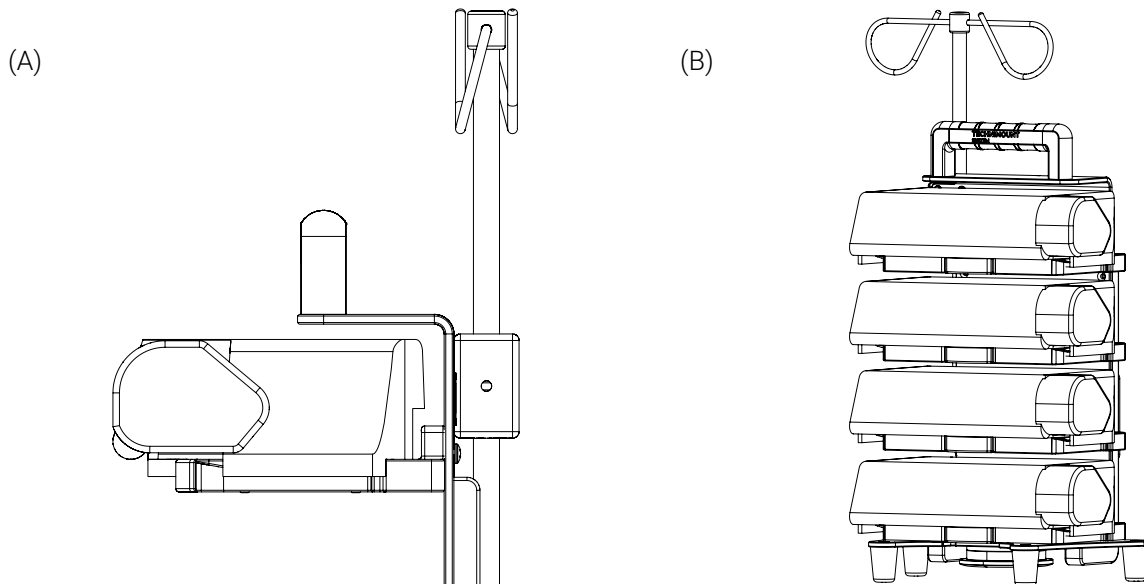

Figure 7: Pump(s) installed in the support bracket

The installation of the pump(s) in the Bracket Pro Serie 80 - FL4 is complete.

6.2. Remove the Pump(s) from the Bracket Pro Serie 80 - FL4

- Unplug the pump(s). Refer to your protocols and the manufacturer's user documentation for the safety guidelines and safe use of the pump(s).
- Press and hold the quick release button at the front of the pump shelf, pull the pump forward horizontally out of the support bracket (Figure 8), then set it aside.

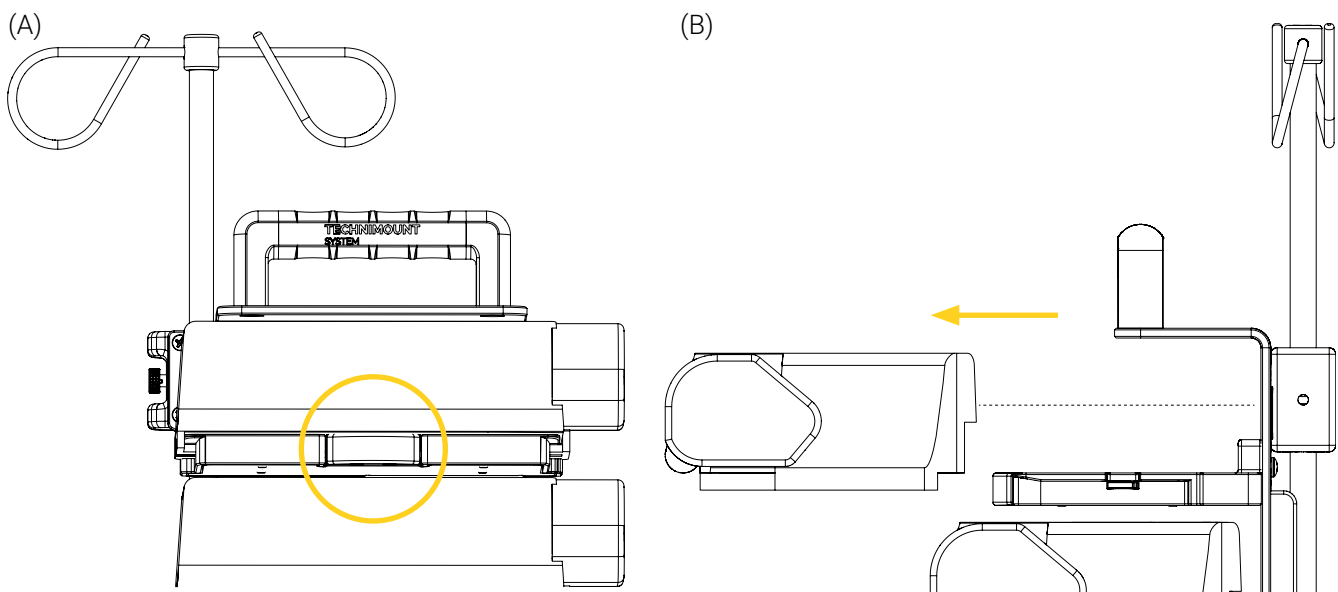

Figure 8: Removing the pump from the pump shelf

- Repeat steps 1 to 2 for the remaining pumps if needed (Figure 9).

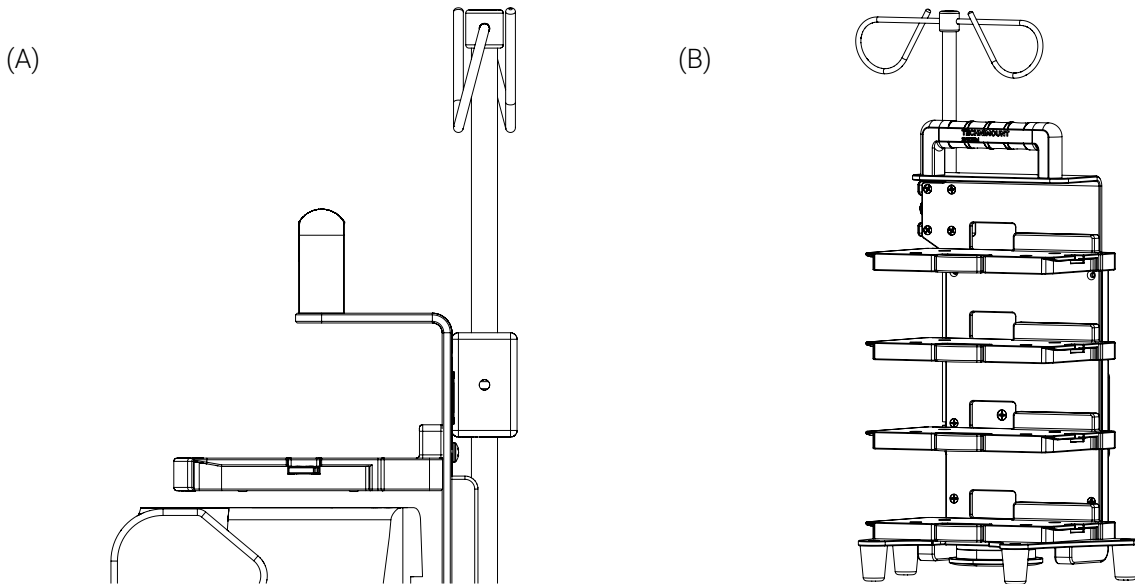

Figure 9: Pump(s) removed from the support bracket

The removal of the pump(s) from the Bracket Pro Serie 80 - FL4 is complete.

6.3. Install the Bracket Pro Serie 80 - FL4 on the Micro Base

- Align and insert the micro disc of the support bracket horizontally (Figure 10) or vertically (Figure 11) in the Micro Base, paying close attention not to wedge the cables of the pumps or accessory cables.

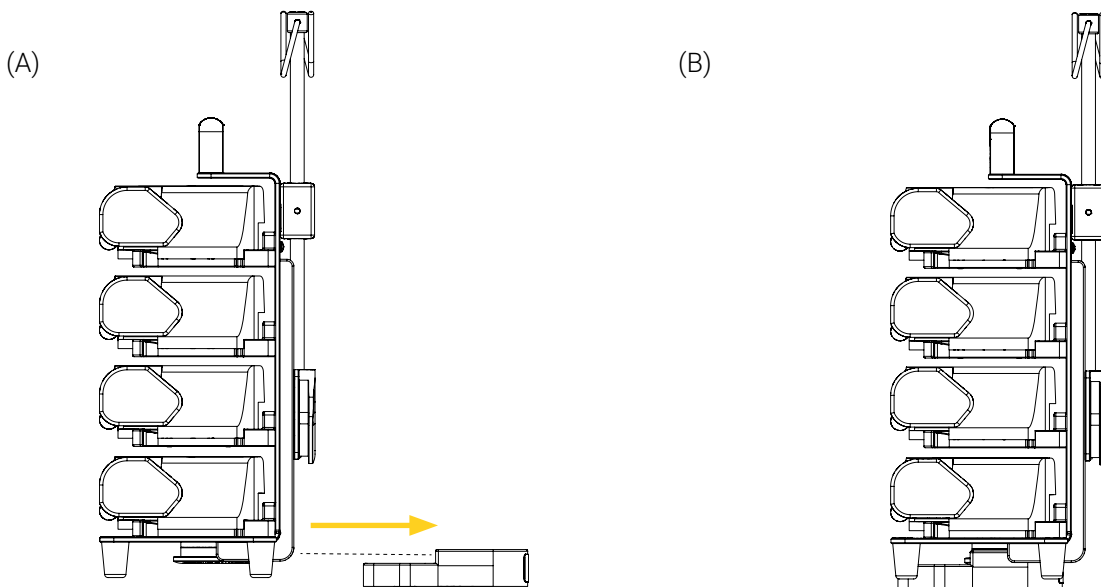

Figure 10: Installing the Bracket Pro Serie 80 - FL4 with a horizontal micro disc in the Micro Base

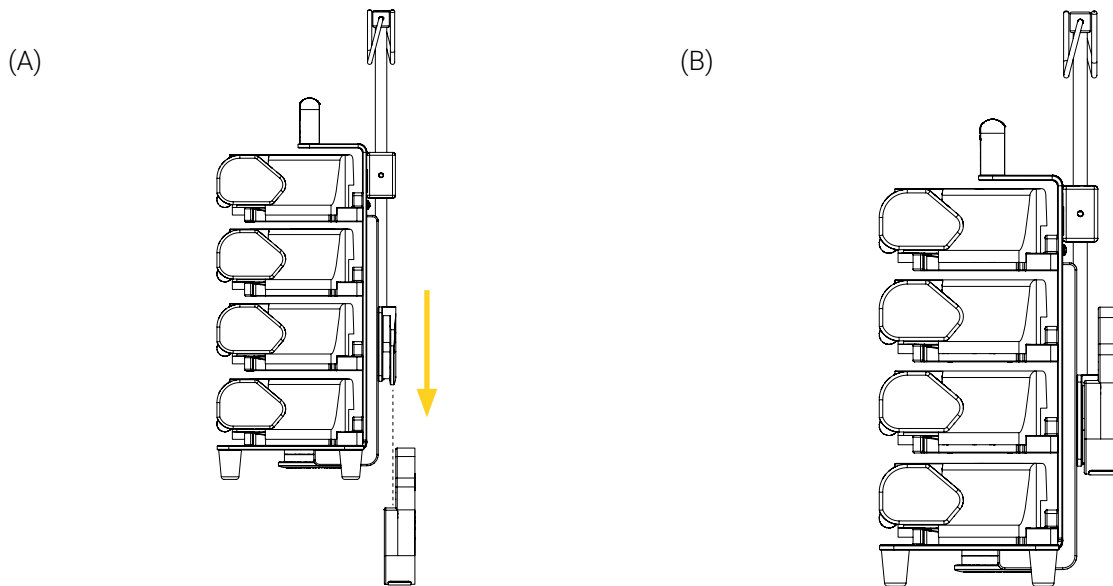

Figure 11: Installing the Bracket Pro Serie 80 - FL4 with a vertical micro disc in the Micro Base

2. Ensure that the support bracket is secured. If the micro disc of the support bracket stays in the Micro Base after the verification, it is properly secured.
3. For installations using the horizontal micro disc, turn the support bracket clockwise or counterclockwise (Figure 12), to the desired position when needed.

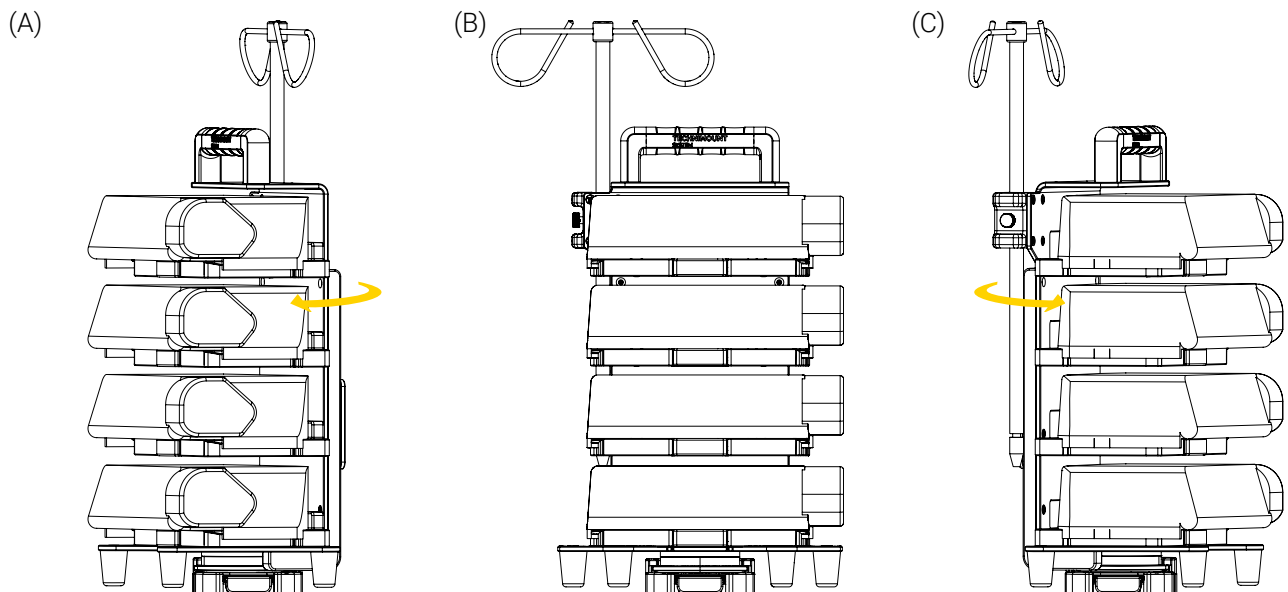

Figure 12: Operating the Bracket Pro Serie 80 - FL4 on the Micro Base

The installation of the Bracket Pro Serie 80 - FL4 in the Micro Base is complete.

6.4. Remove the Bracket Pro Serie 80 - FL4 from the Micro Base

Press and hold the quick release button of the Micro Base, then slide the micro disc of the support bracket forward horizontally (Figure 13) or vertically (Figure 14) out of the base.

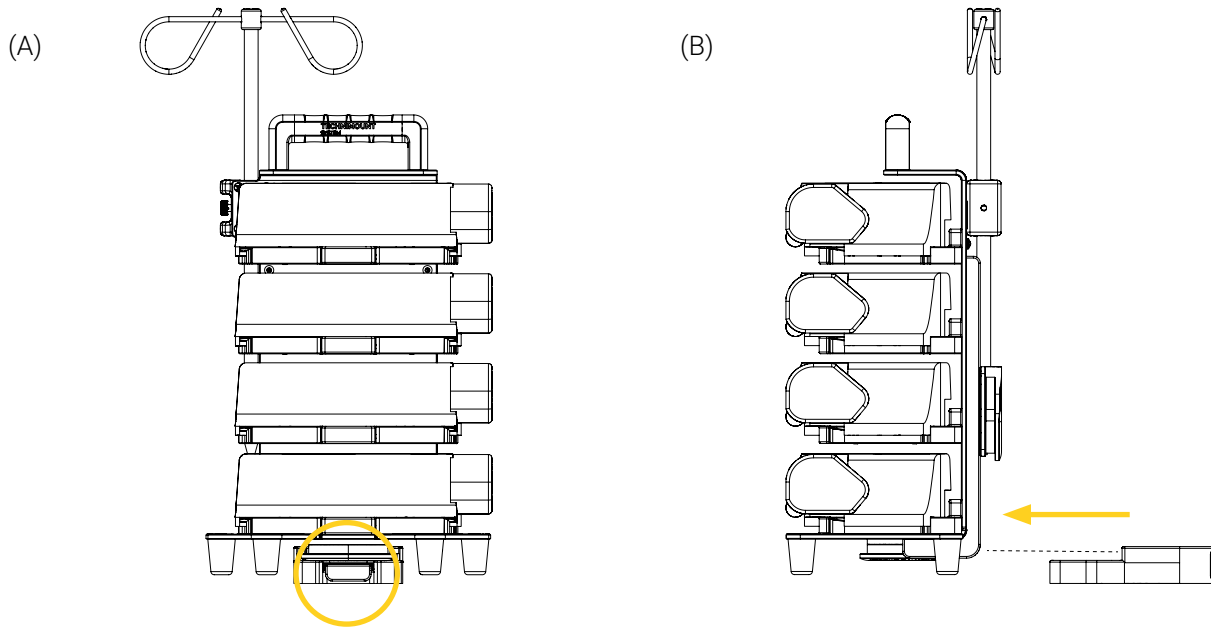

Figure 13: Removing the Bracket Pro Serie 80 - FL4 with a horizontal micro disc from the Micro Base

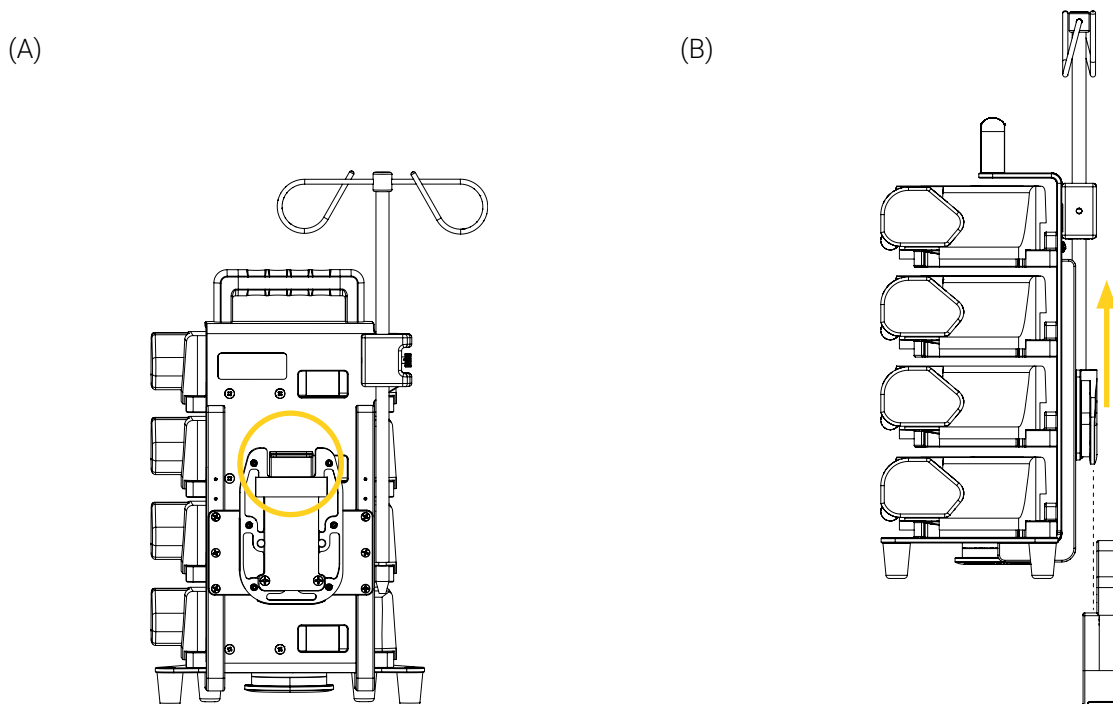

Figure 14: Removing the Bracket Pro Serie 80 - FL4 with a vertical micro disc from the Micro Base

The removal of the Bracket Pro Serie 80 - FL4 from the Micro Base is complete.

6.5. Operate the IV Pole

To lower or raise the IV pole,

1. Pull and hold the quick release knob of the IV pole holder, then adjust the height of the IV pole to your specific positioning needs when needed (Figure 15). Refer to the « 2.3. Safety Measures » on page 11 if needed.
 - Raise the IV pole and secure in the bottom groove (Figure 15).
 - Lower the IV pole and secure in the top groove (Figure 15).

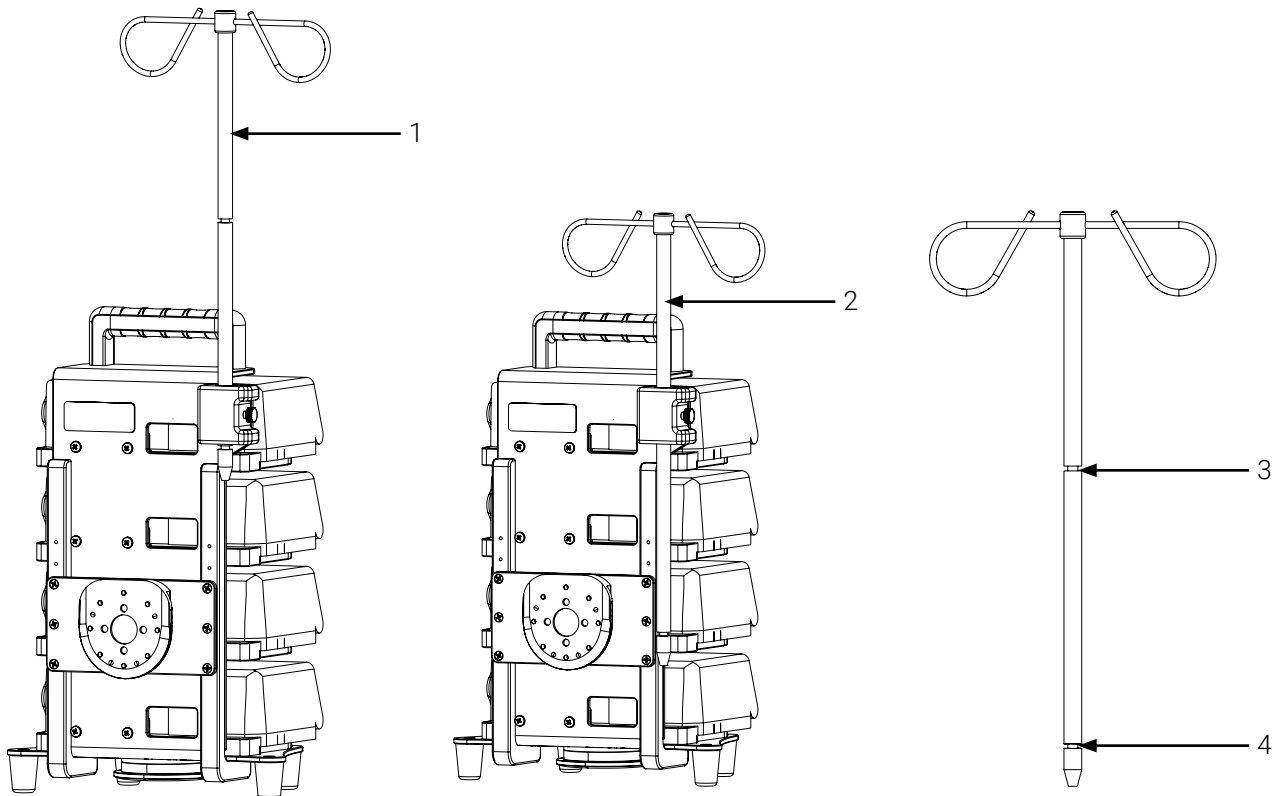

1. High position

2. Low position

3. Top groove (max. low position)

4. Bottom groove (max. high position)

Figure 15: Lowering/raising the IV pole

2. Turn the IV pole clockwise or counterclockwise (Figure 16) to the desired position when needed.

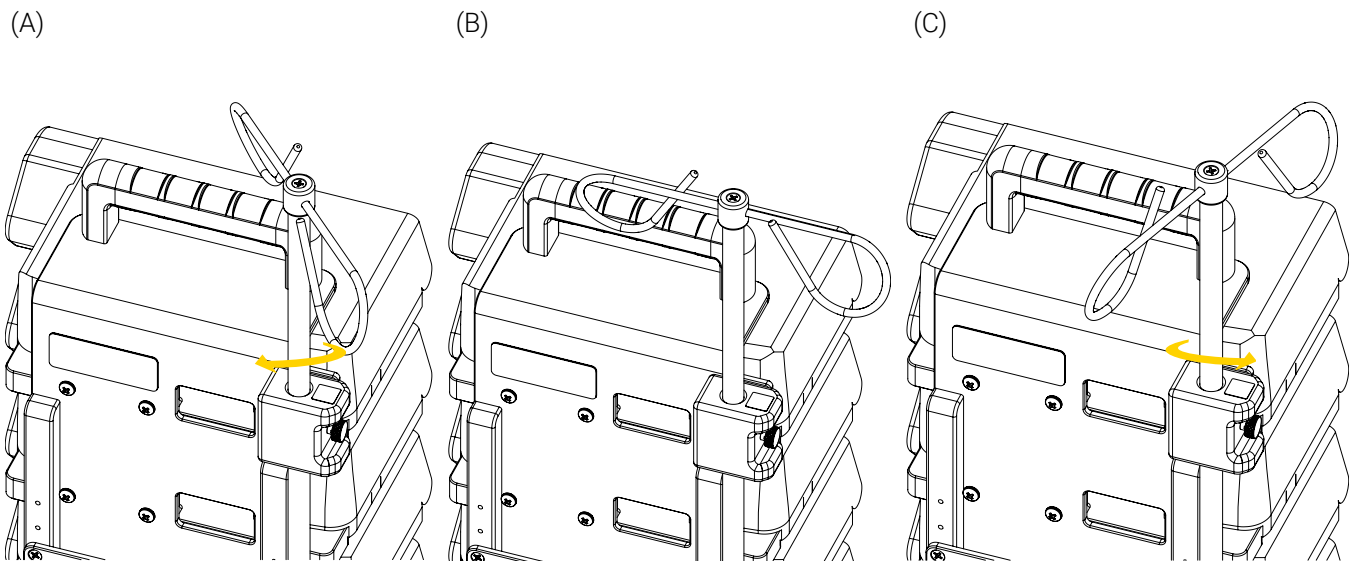

Figure 16: Rotating the IV pole

3. Release the quick release knob.
4. Ensure that the IV pole is secured. If the IV pole does not slide down the holder and stays in the place after the verification, it is properly secured.

Annex I EMS and clinical personnel Skills Assessment

Following training, a skills assessment should be given to each member of the EMS and clinical personnel to ensure they have fully comprehended the labelling, warnings and cautions, potential risks, safe practices and proper operating procedures needed to safely and effectively use the support bracket. Consider adding the following to your internal training protocols.

Trainee name: _____ Unit: _____

Assessor name: _____ Date: _____

EMS AND CLINICAL PERSONNEL SKILLS ASSESSMENT

SKILL CRITERIA	PASSED	FAILED
----------------	--------	--------

Labelling

Able to identify meaning and potential risks associated with the different safety labels:

- Safe Working Load (SWL).
- Pinch Point/Hand Crush

Safety Measures

- Knows not to use the IV pole during transport and to always ensure that the IV pole is lowered and secured in the IV pole holder.
- Knows to always ensure that the IV pole is secured in one (1) of the two (2) grooves of the IV pole holder.
- Knows to always ensure that the medical device(s) and IV pole are properly secured in the support bracket before it is moved.
- Knows to always pay close attention to the condition of the safety mechanisms of the support bracket and the IV pole.
- Knows to ensure that the medical device(s) are secured in the support bracket before they are moved.
- Knows not to overload the support bracket.

Operation

- Able to install/remove the pump(s) in/from the support bracket.
- Able to install/remove the support bracket in/from a Micro Base.
- Able to operate the IV pole.
- Has practiced safely operating the support bracket, has perfected the manipulations and has acquired the required skill level to safely use with patient.

Annex II Unpack the Bracket Pro Serie 80 - FL4

Unpacking should be reserved for biomedical technicians (or equivalent) who have extensive mechanical experience, and advanced skill level.

1. Inspect the shipping box(es) for signs of damage before accepting shipment. Take pictures and report them promptly when applicable.
2. Move the shipping box(es) to the location of the installation.
3. Open the shipping box(es).
4. Unpack the box(es) and ensure that all shipping and packaging materials have been properly removed, prior to installation.

NOTE : Keep all packaging material for future use.

5. Identify all the components and hardware included for the installation when applicable, then set aside. Refer to Annex III on page 29 for the required parts.
6. Inspect the items for signs of damage. Take pictures and report them promptly when applicable.

Annex III Prepare the support bracket

The contents in this section is intended for biomedical technicians (or equivalent) who have extensive mechanical experience, and advanced skill level and have read the « Safety Measures » on page 11.

Install the IV Pole in the IV Pole Holder

1. Identify the assembly parts (Figure 17).

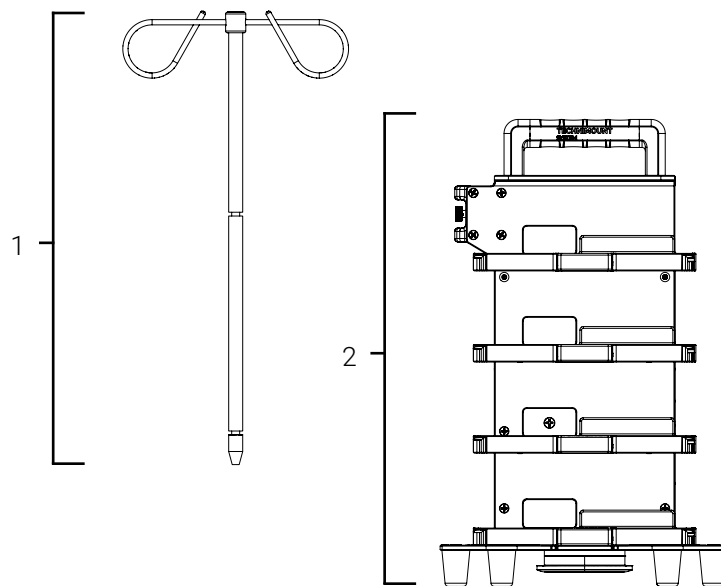

1. IV pole

2. Support bracket

Figure 17: Bracket Pro Serie 80 - FL4 assembly parts

2. Locate the quick release knob on the IV pole holder (Figure 18).

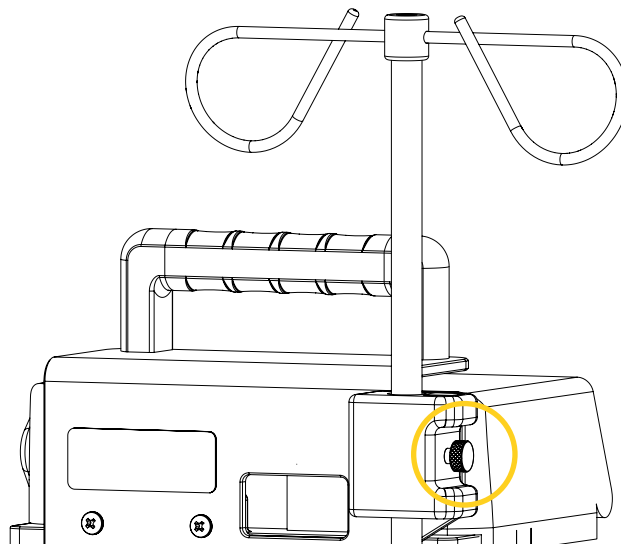

Figure 18: Locating the quick release knob of the IV pole holder

3. Pull and hold the quick release knob, then align and insert the IV pole in the holder until it is secured in one (1) of the two (2) grooves (Figure 19). Refer to the « 2.3. Safety Measures » on page 11 if needed.

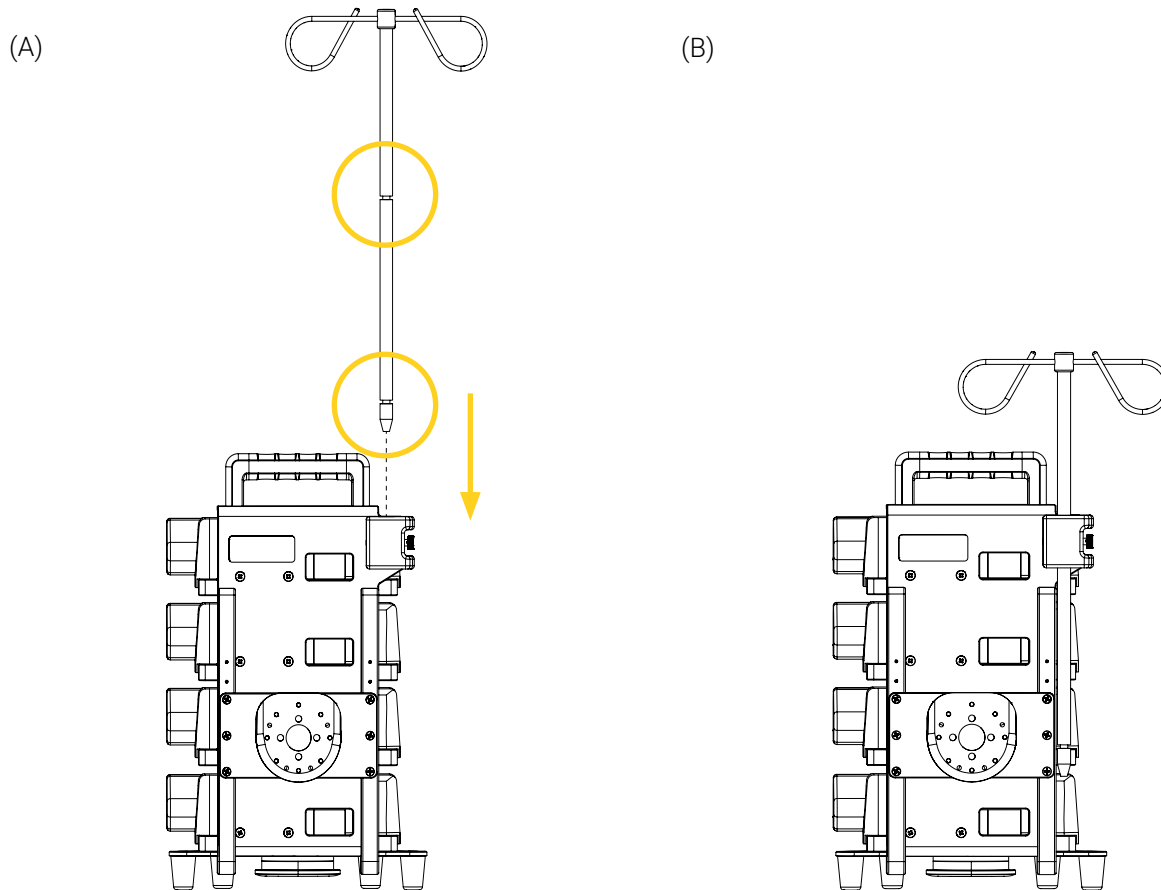

Figure 19: Installing the IV pole in the IV pole holder

4. Release the quick release button.
5. Ensure that the IV pole is secured. If the IV pole does not slide down the holder and stays in the place after the verification, it is properly secured.

The installation of the IV pole in the IV pole holder is complete.

Annex IV Maintenance

Safety checks and condition-based maintenance should be carried out by biomedical technicians (or equivalent) who have extensive mechanical experience, and advanced skill level and have read all the « Safety Measures » on page 11, and the maintenance specific safety measures listed below.

Factors such as weather, environment, geographical location and individual usage will necessitate different needs. For the maintenance of the Bracket Pro Serie 80 - FL4, follow the guidelines listed herein and in accordance with your service's current maintenance practices and protocols. Please contact Technical Support at techsupport@technimount.com for replacement parts or repair related issues, if needed.



WARNING – General Warning

- **Do not** perform safety checks or condition-based maintenance before having read the entire content of the user manual, gained in-depth knowledge and product comprehension, and familiarized yourself with the standards and guidelines.
- Safety checks and a condition-based maintenance plan are required and should be established for all Technimount products.
- Perform the safety checks and maintenance operations as described herein. Failing to follow the recommended maintenance plan or its guidelines could cause premature damage to the product.
- Use only Technimount parts, maintenance procedures, cleaning solutions and lubricants, as described herein. Using unapproved modified parts or procedures for the maintenance of the Technimount product may cause the system to be unstable and could cause injury to the patients or EMS and clinical personnel and void the product warranty.
- Replace damaged or worn-out parts if past their expected service life or when damaged (refer to « Annex V Replacement Parts/Kits » on page 37). Recycle damaged parts or dispose according to the environmental laws that apply to your jurisdiction and consult the Safety Data Sheets (SDS).



CAUTION – Safe Handling and Operation

- **Do not** use powered tools to screw the hardware during installation, as there is a potential risk of damage to the threads.
- **Do not** steam clean or use ultrasonic cleaners on the system or any of its components.
- **Do not** immerse the metal parts/components in water.
- To spot clean, the maximum water temperature should not exceed 180° F/82° C. The maximum water pressure should not exceed 1500 psi/103.5 BAR. If using a high pressure washer, the pressure nozzle must be kept a minimum of 24 in. (61 cm) from the unit.
- When cleaning, always use appropriate Personal Protection Equipment (PPE) based on established protocols (e.g., gloves, eyewear, etc.).



CAUTION – Corrosion

- Always rinse and dry the support bracket properly after using cleaning products. Certain types of cleaners may leave a corrosive residue on the surface of the product and could cause the premature corrosion of critical components. Refer to the product Safety Data Sheets (SDS) for chemical information or handling, storage and emergency measures in case of accident.
- Dispose of corrosive wastes according to the environmental laws that apply to your jurisdiction and consult the Safety Data Sheets (SDS).

**CAUTION – Follow Instructions for Use**

Always read and abide by all the safety guidelines identified, as well as follow instructions provided by the manufacturer of the cleaning product.

Maintenance Frequency

- Safety checks and the condition-based maintenance should be performed minimally every month or as frequently needed, to prolong the longevity of the support bracket in optimal conditions.
- Decontaminate the support bracket as recommended in your internal protocols, as well as the regulations and standards in virtue of the infection prevention and control procedures.

Required Tools

- Clean dry cloths
- Soft brush
- Pressure washer
- Cleaning solutions
- Medium strength thread lock adhesive (🔹)
- Phillips screwdriver

Tested Cleaning Solutions

- Oxivir, 5% Hydrogen Peroxide with Peracetic Acid (AHP)
- Lavo 12, 10 000 ppm Sodium Hypochlorite
- TNT-100, 5% Quaternary Ammonium Compound
- Spectro-Sept, 5% Ethyl Alcohol
- Spectrol, 5% EDTA salt

Maintenance Plan

NOTE : In case of a non-conformity, stop using the product and contact Technical Support at techsupport@technimount.com immediately for a remedial action plan.

NOTE : Always keep records of your maintenance activities and immediately remove defective or expired products from your inventory.

MAINTENANCE PLAN	COMPLIANT	
SAFETY CHECKS	YES	NO

Bracket Pro Serie 80 - FL4 (Figure 20)

- Visually inspect all the components of the support bracket, IV pole and micro disc to ensure there is no damage or chemical attack, that the hardware is in good condition and there are no loose screws:
 - IV pole
 - IV pole holder
 - Handle
 - Micro disc
 - Anti-rotation micro disc
 - Feet (4X)
- If there is damage to the components, remove the product from circulation and contact Technical Support immediately for a remedial action plan.
- If there are traces of chemical attack, follow the conditioned-based maintenance herein.
- If the hardware is not in good condition, replace it. Contact Technical Support if needed.
- If the hardware is loose, apply medium strength thread lock adhesive and tighten using a Phillips screwdriver.
- Visually inspect the cavities of the safety mechanisms of each shelf and the IV pole holder and make sure there are no lodged particles to ensure proper functioning. If so, immediately remove using a clean dry cloth.
- Ensure that the IV pole is secured in the IV pole holder. The IV pole should be secured in one (1) of the two (2) grooves. If not, immediately cease use and contact Technical Support.
- Insert/remove the pump(s) on/from the pump shelves a few times to ensure proper functioning of the locking mechanism. The pump should be easily inserted and locked in position after the click sound and easily removed when using the quick release button. If not, immediately cease use and contact Technical Support.

MAINTENANCE PLAN	COMPLIANT	
------------------	-----------	--

SAFETY CHECKS	YES	NO
<ul style="list-style-type: none"> - Insert/remove the micro disc and anti-rotation micro disc in/from the Micro Base a few times to ensure proper functioning of the locking mechanism. The disc of the support bracket should be easily inserted and locked in position after the click sound and easily removed when using the quick release button. If not, immediately cease use and contact Technical Support. 	<input type="checkbox"/>	<input type="checkbox"/>

CONDITION-BASED MAINTENANCE	YES	NO
-----------------------------	-----	----

Following the safety checks,

<p>Clean the Bracket Pro Serie 80 - FL4</p> <ol style="list-style-type: none"> 1. Remove the excess dirt using a clean cloth, if needed. 2. Remove the contaminants using a pressure washer or as recommended in your internal protocols and control procedures. 3. Clean using a cloth and cleaning solution. 4. Spot clean stains by applying the solution directly on the stain and let sit on the surface, if needed. <p style="margin-left: 40px;">NOTE : Avoid over saturation and ensure that the product does not sit on the surface of the support bracket longer than recommended by the cleaner's manufacturer.</p> 5. Thoroughly rinse the solution with a clean cloth dampened with lukewarm water, then dry all the components using a clean cloth before returning to service. 	<input type="checkbox"/>	<input type="checkbox"/>
---	--------------------------	--------------------------

Comments and observations following the Safety Checks and Condition-Based Maintenance:

Maintenance plan completed on (dd/mm/yyyy):

Maintenance plan completed by:

Illustrated Inspection Points

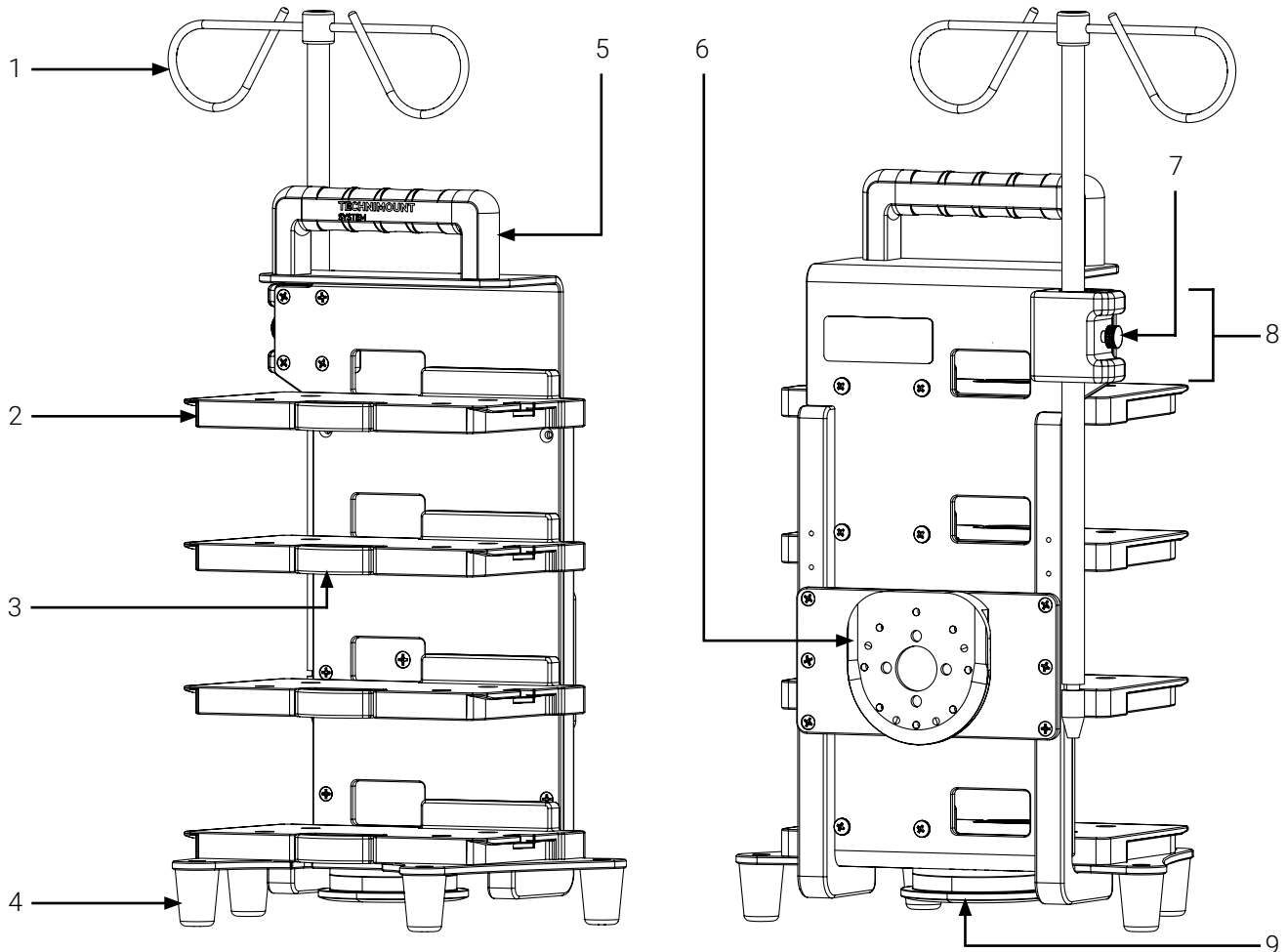

- | | |
|--|---|
| 1. IV pole | 6. Anti-rotation micro disc (vertical) |
| 2. Pump shelf (4X) | 7. Quick release knob/Height adjustment (IV pole) |
| 3. Quick release button (pump shelf; 4X) | 8. IV pole holder |
| 4. Feet (4X) | 9. Micro disc (horizontal) |
| 5. Handle | |

Figure 20: Illustrated inspection points

Annex V Replacement Parts/Kits

Technimount reserves the right to change part numbers and products without notice. Please contact Customer Service at customerservice@technimount.com to ensure product options and availability, or Technical Support at techsupport@technimount.com for replacement parts/kits or repair related issues.

PART/KIT NUMBER	PART/KIT DESCRIPTION
840-10-IV2-16	IV pole
923-00-1282-INS	1-9/32 in. acetal foot (hardware included)



TECHNIMOUNT
EMS®

SAFETY AND FLEXIBILITY
WHERE IT MATTERS MOST