



TECHNIMOUNT
MEDICAL®

THS® NEONATAL CART

TRANSPORT CART FOR DRÄGER BABYLEO® TN500
INCUBATOR & MULTIPLE MEDICAL DEVICES



**MAKING HEALTHCARE PRACTICES
MORE EFFICIENT**

THS[®] NEONATAL CART

Product Components

Designed for the diligent world of neonatal care, the THS Neonatal Cart is a robust and versatile solution tailored for intra-hospital transport of the Dräger Babyleo incubator. Customizable with various accessories, it allows healthcare personnel to tailor the cart to their specific needs, ensuring safe and efficient transport of newborns.

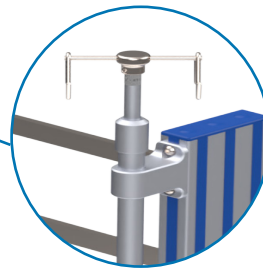
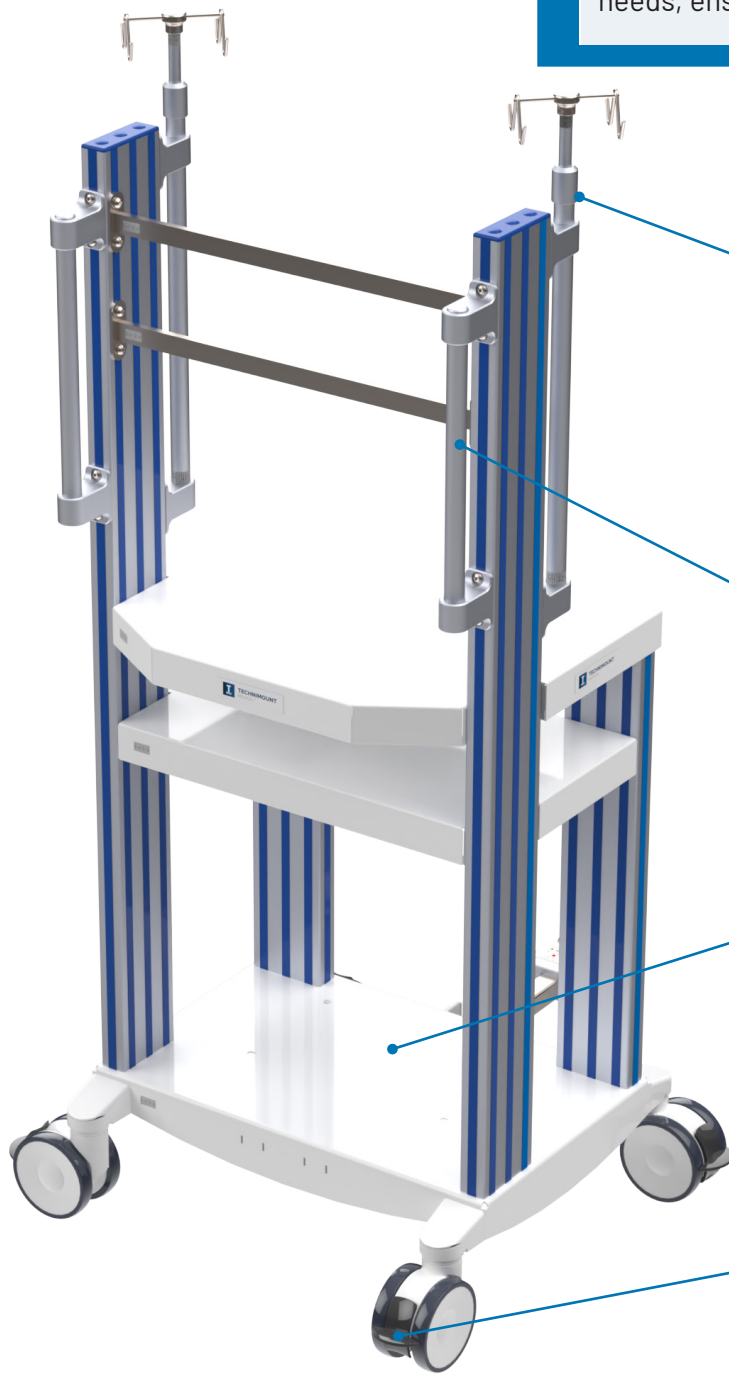

Extendable IV poles providing adjustable height

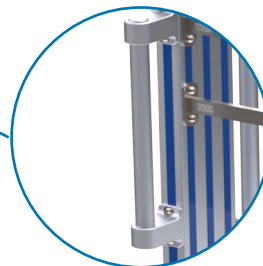

Vertical handles for convenient maneuverability

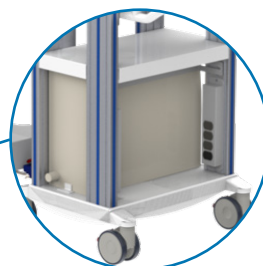

Reinforced UPS shelf with UPS on-off switch protective panel



Four dual wheel swivel casters with braking system

THS[®] NEONATAL CART

Product Components

With increased capacity for managing multiple medical devices efficiently, it also offers interchangeability between devices. Its smooth-gliding dual casters make it easy to maneuver, while the integrated handles enable ergonomic handling during transport.

Vertical and horizontal rail system for various medical device configurations

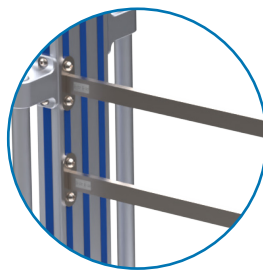

Top shelf offering further storage

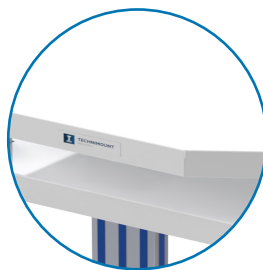

Fold-up hitch providing greater leg clearance

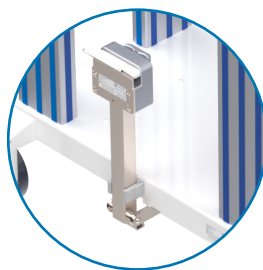

Quick release mechanism on the fold-up hitch

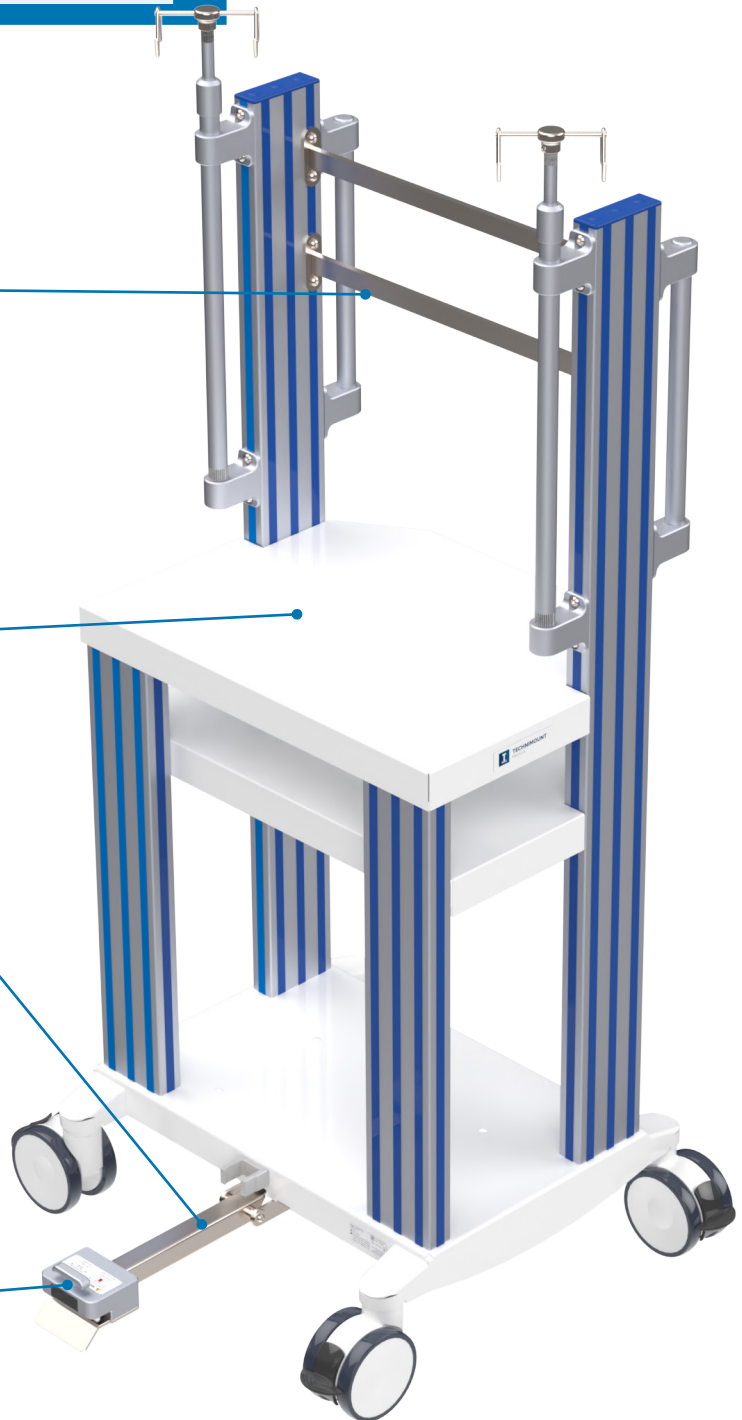

THS[®] NEONATAL CART

Main Highlights

FEATURES & BENEFITS

- Secures Dräger's incubator and various medical devices for safe intra-hospital transport.
- Responds to mobility needs allowing for effortless gliding and smooth maneuverability.
- Increases efficiency by maximizing medical device space through vertical and horizontal rail systems, ensuring easy access and visibility at all times.
- Improves user experience with ergonomic handles catering to all heights.
- Enables the support of heavy medical devices with a robust cart.
- Offers a UPS shelf, enabling uninterrupted power supply.
- Secures gas cylinders for easy transport and safety.
- Enhances versatility with THS coupling device at either front or end of the incubator, allowing for seamless configuration changes.
- Simplifies workflow with a fold-up hitch featuring an easy quick release mechanism.
- Promotes efficient maneuvering with four dual wheel casters equipped with a braking system.
- Facilitates ongoing clinical care and newborn safety.
- Tested in compliance with IEC 60601-1 Ed. 3 for reliability and safety assurance.

THS Coupling Device (Patient Foot End)

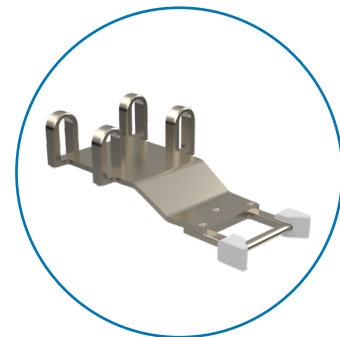
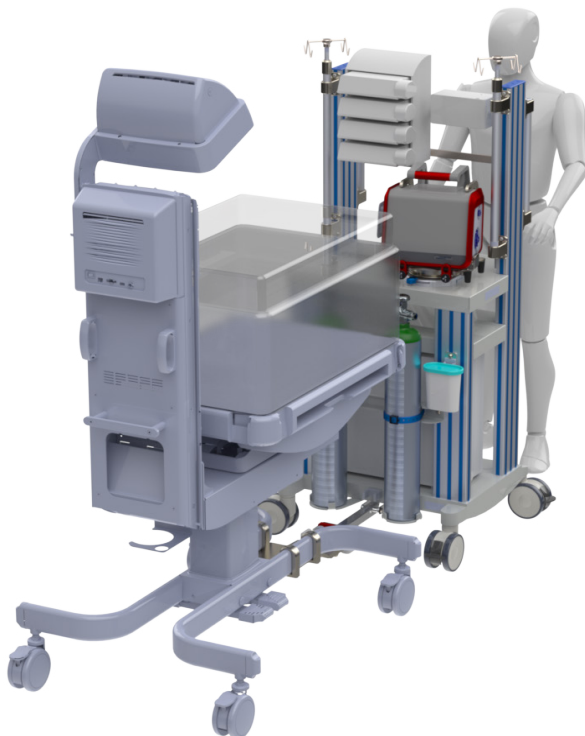

The THS coupling device can be installed under the incubator at patient head end or patient foot end.

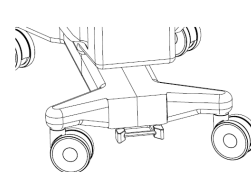

Patient Head End

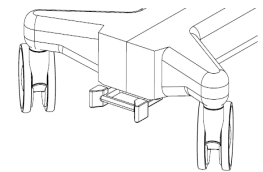

Patient Foot End

THS[®] NEONATAL CART

Possible Configurations



Universal Mounting Base



Support plate for Dräger mounting system with SLIDE adapter

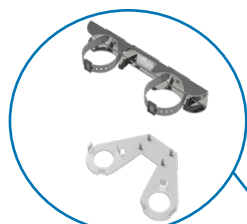

Type D-M15 & E-M24 mounting bracket



Support plate for the Serres suction canister

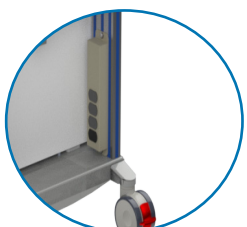

Medical grade power bar with surge protection



UPS cable management hook

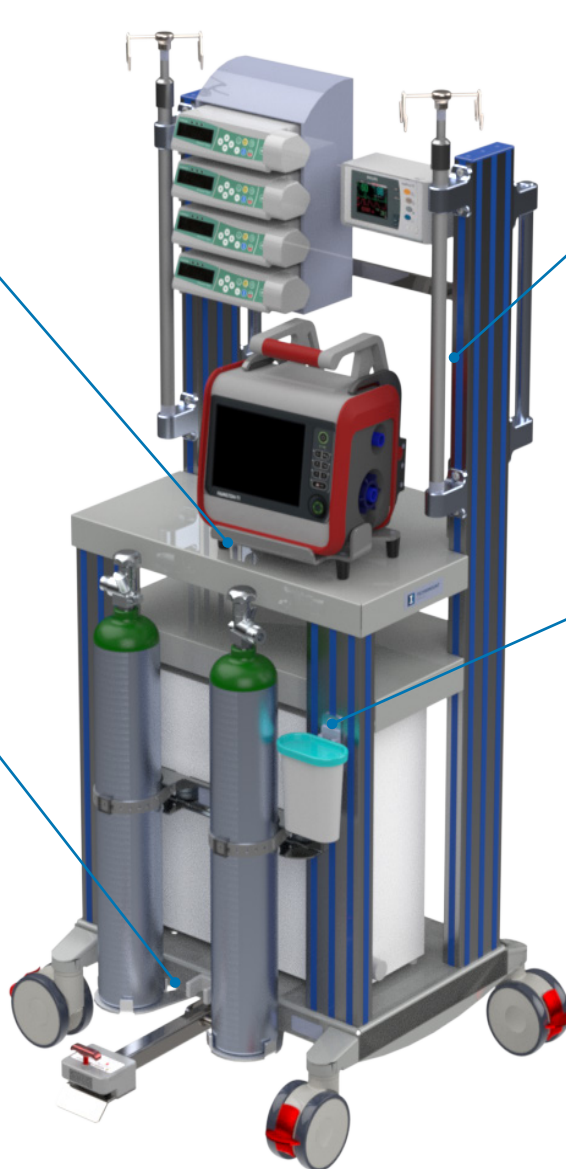

THS[®] NEONATAL CART

Technical Specifications

Product Name	THS [®] Neonatal Cart
Description	Transport cart designed to aid trained clinical staff move the Dräger Babyleo TN500 [®] incubator and the multiple medical devices that are essential to neonates during intrahospital transfers
Product Code	MED-FB5EP2I4T
Operating Environment	Hospital
Compliance	Tested in compliance with IEC60601-1 (applicable mechanical sections)
Compatible Mounting System	Babyleo TN500 [®] Incubator
Dimensions (L X P X H)	<ul style="list-style-type: none">• Transport cart (w/o options or accessories): 25.75 in. X 23.25 in. X 64 in. (65.3 cm X 59 cm X 162.6 cm)• THS coupling device: 9.2 in. X 6.8 in. X 2 in. (22.9 cm X 15.3 cm X 5.1 cm)
Weight	<ul style="list-style-type: none">• Transport cart (w/o options or accessories): 120 lb (54.5 kg)• THS coupling device: 2.4 lb (1.1 kg)
Composition	<p>Transport cart: aluminum 6061-T6, silver anodized finish and stainless steel, gray powder paint</p> <ul style="list-style-type: none">• THS coupling device: aluminum 6061-T6, silver anodized finish, white acetal and stainless steel• Fold-up hitch: stainless steel, acetal and aluminum, silver anodized finish• Rail system: stainless steel• Handles: aluminum 6061-T6, silver anodized finish• IV poles: aluminum 6061-T6, silver anodized finish and stainless steel• 4-in. dual wheel swivel casters with braking system: polyamide and polyurethane
Total Safe Working Load (SWL)	<ul style="list-style-type: none">• Transport cart: 300 lb (136.1 kg)• Transport cart components:<ul style="list-style-type: none">• Top shelf, UPS protector/shelf: 60 lb (27.22 kg), per shelf• UPS shelf: 150 lb (68.04 kg)• Horizontal rails: 40 lb (18.14 kg), per rail• IV poles (top part): 4.5 L (160 oz liq.), per pole• IV poles (bottom part): 20 lb (9.07 kg), per pole

THS[®] NEONATAL CART

Technical Specifications

Operating Temperature

-31° F to 113° F (- 35° C to 45° C)

Options

- Type D-M15 and type E-M24 mounting bracket for 2 gas cylinders, OXY-10-DCF
- Type D-M15 and type E-M24 mounting bracket for 4 gas cylinders, OXY-40-DCF
- Support plate for the Dräger mounting system with SLIDE adapter, SUP-10-ARM
- Support plate for the Serres[®] suction canister, SUP-10-SUC
- Medical grade power bar with surge protection (4 or 6 outlets), 3000-00-PS-407
- UPS on-off switch protective panel for the Ametek[®] Powervar unit, model 50220-72R, SUP-10-UPS
- Cable management hook, 9012-10-UPS

THS Neonatal Cart Measurements

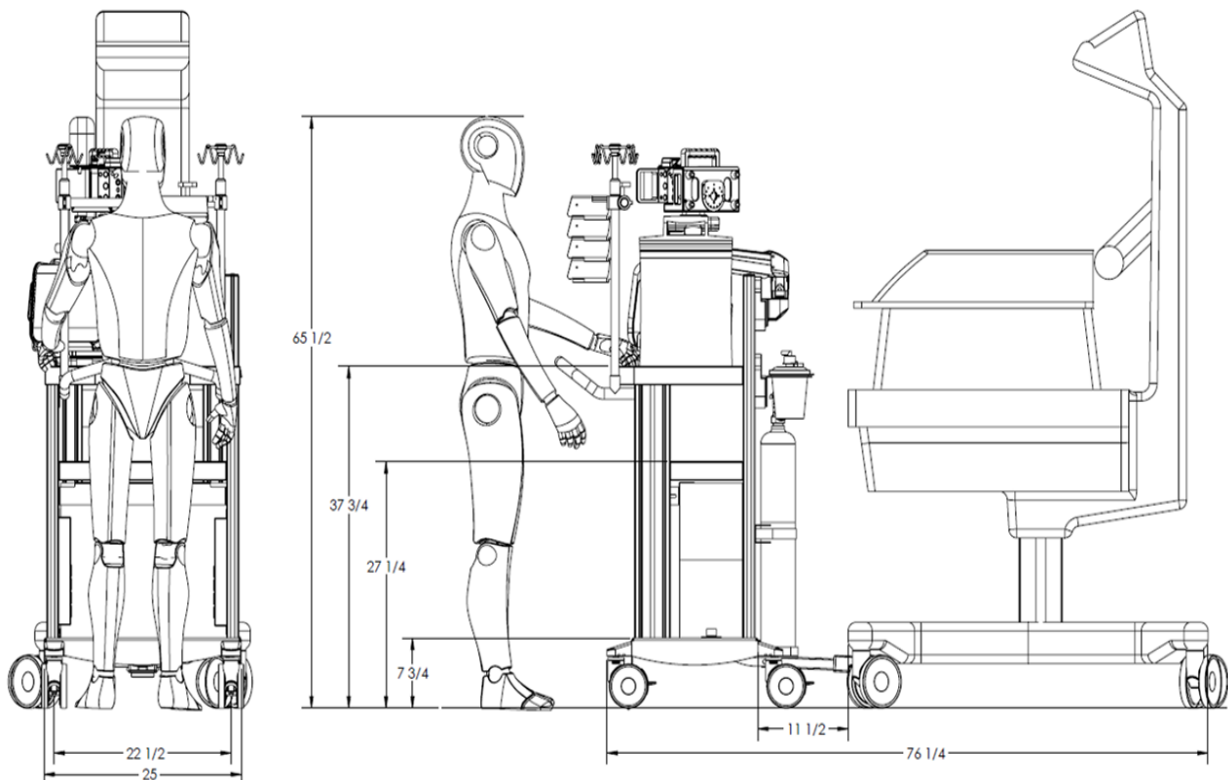



TECHNIMOUNT
MEDICAL®

At Technimount Medical Inc., we understand that healthcare professionals need equipment that makes their everyday practice easier. We design and develop quality solutions that are flexible and easy to use, allowing them to focus on what matters most - patient care.

Technimount Medical follows the same path as Technimount System, continuously innovating to make healthcare practices more efficient and safer. Since its inception in 2013, Technimount System has been recognized as the leader in the Emergency Medical Services' industry, setting the standard in safe and flexible mounting systems for medical devices.

With the same mindset, Technimount Medical, an ISO 13485 certified company, creates distinctive products that respond to the ever-evolving healthcare practices. Our Technimount Healthcare System™ (THS™) and Healthcare Essentials product lines enable caregivers to move efficiently and safely all the medical devices needed to successfully treat their patients, wherever they are inside the hospital or remotely via telemedicine systems.

TECHNIMOUNT MEDICAL INC.
Corporate Headquarters
3770 Jean Marchand Street, Suite 100-B
Quebec (QC) G2C 1Y6
Canada
T + 1 581.700.6583
TF + 1 888.521.0871
info@technimount.com
technimount.com

